

VENTACITYSYSTEMS

Making Buildings Healthy - Efficient - Smarter



VS3000 RT

Installation and Operation Manual

Rev 02.06



10 111 54 - EN
10 111 55 - FR







12/02/22

TABLE OF CONTENTS

1. INTRODUCTION	
1.1 Acceptable Environment	5
1.2 Safe Installation Distance	5
2. SPECIFICATIONS	
2.1 System Overview	6
2.2 Main Components	7
2.3 General Specifications	8
2.4 Fan Performance	9
2.5 Dimensions	10
3. PLANNING	
3.1 Information Collection	12
3.2 Down Ducted Overview	13
3.3 Side Ducted Overview	13
3.4 Condensate Drain	14
3.5 In-Depth Examples & Considerations	15
4. INSTALLATION	
4.1 Roof & Building Prep	18
4.2 HRV Prep	18
4.3 Physical Installation	20
4.4 Electrical Installation	22
4.5 Procedure for SBC100 Wiring	28
4.6 Deactivate Preheater	29
5. COMMISSIONING	
5.1 Activation	30
5.2 Main Display	30
5.3 Main Menu	30
5.4 Service Menu	31
6. REFERENCE	
6.1 Maintenance (Filter Replacement / Cleaning)	39
6.2 Troubleshooting	40
6.3 Service (How to Find Firmware and Serial Number)	44
6.4 Accessories	44
6.5 Conclusion	45

1. INTRODUCTION

This manual includes the following symbols.

Symbol		Meaning
	<i>ATTENTION!</i>	Warning or notification
	<i>READ CAREFULLY!</i>	Important instructions
	<i>YOU WILL NEED</i>	Advice and practical information
	<i>TECHNICAL DATA</i>	Detailed technical information

This manual includes important instructions for safe connection of the Heat Recovery Ventilator unit (HRV). Before connecting the unit, please read carefully and follow all the instructions below! The manufacturer reserves the right to make changes, including changes in the technical documentation, without previous notification. Please keep this manual for further reference. Consider this manual a permanent part of the product.

- This manual shows manufacturer-recommended installation methods. Local codes and regulations override these recommendations.
- The installation must follow local codes and standards as approved by local permitting authorities and National Electrical Code (NEC), The National Fire Protection Agency (NFPA), and the Canadian Electrical Code (CEC) in Canada.
- Installation must be performed by qualified and accredited professional engineers and skilled tradesmen in conformance with local and national codes, standards, and licensing requirements.

EC DECLARATION OF CONFORMITY

The product was designed, manufactured, and placed on the market, and complies with all relevant provisions and requirements of the European Parliament and the Council, including amendments, which it was classified under. The product is safe under normal conditions of installation and use. The conditions are defined in the Operating Instructions. The product's safety evaluation was based on the harmonized European standards listed in the relevant EC declaration of conformity.

During installation it is necessary to consider the weight of the unit, including all associated peripherals. The heat recovery unit project shall be always developed by an HVAC designer.

FCC CLASS A STATEMENT

NOTE: This equipment has been tested and found to comply with the limits for a Class A digital device, pursuant to Part 15 of the FCC Rules. These limits are designed to provide reasonable protection against harmful interference when the equipment is operated in a commercial environment. This equipment generates, uses and can radiate radio frequency energy and, if not installed and used in accordance with the instruction manual, may cause harmful interference to radio communications. Operation of this equipment in a residential area is likely to cause harmful interference in which case the user will be required to correct the interference at his own expense.

IMPORTANT: Changes or modifications to this product not authorized by the manufacturer could void your authority to operate the equipment.

1. INTRODUCTION

1.1 ACCEPTABLE ENVIRONMENT

TECHNICAL DATA

The unit is intended for indoor or outdoor installation and may be installed in the outdoor unprotected environment with the temperature -13 °F to 122 °F (-25 °C to +50 °C)



For proper operation the temperature inside the HRV should range from -13 °F to 122 °F (-25 °C to +50 °C), maximum humidity 90%. Damage to the heat exchanger structure may result if operated outside these limits.

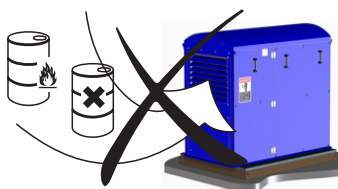

The unit is not designed for air containing flammable or explosive mixtures, chemical vapors, heavy dust, soot, grease, toxins, pathogenic organisms, etc.

TECHNICAL DATA

All models of this type of HRV unit must be installed in a vertical position according to the drawing below.

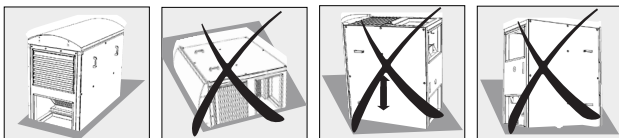

The unit must be installed so that the exhaust air flows in the same direction as the air in the distribution ducts.

The unit must be installed so that maintenance, repairs, or disassembly can be done. In particular, this means providing access to inspect and open dampers, access to the control unit box cover, access to connections on the side of the unit, and to the air filter cover.

1.2 SAFE INSTALLATION DISTANCE

ATTENTION!

Non-flammable materials

- All materials used within 4 inches (100 mm) of the HRV unit must be non-flammable (they do not burn, flame up, burn out) or minimally flammable (they do not burn or decompose, e.g. drywall). Moreover, these materials must not cover the unit's inlets or outlets.

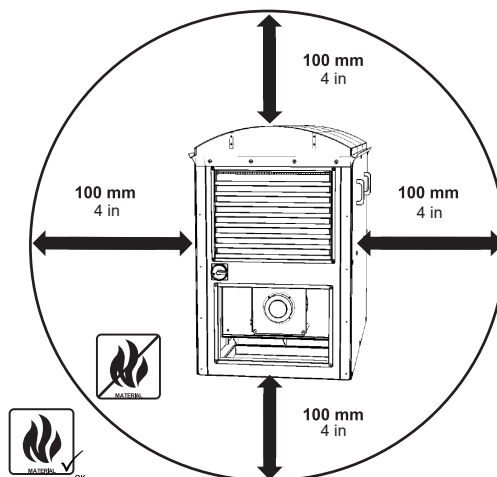

Minimally flammable materials

- The minimum safe distance of flammable materials from the unit's outlets is 20 inches (500 mm).
- The minimum safe distance of flammable materials in other directions is 4 inches (100 mm).

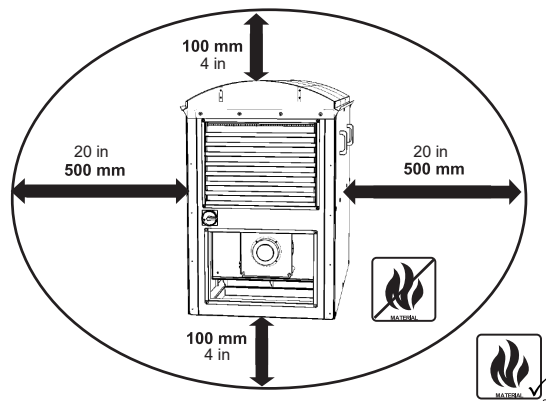

2. SPECIFICATIONS

2.1 SYSTEM OVERVIEW

SPECIFICATIONS

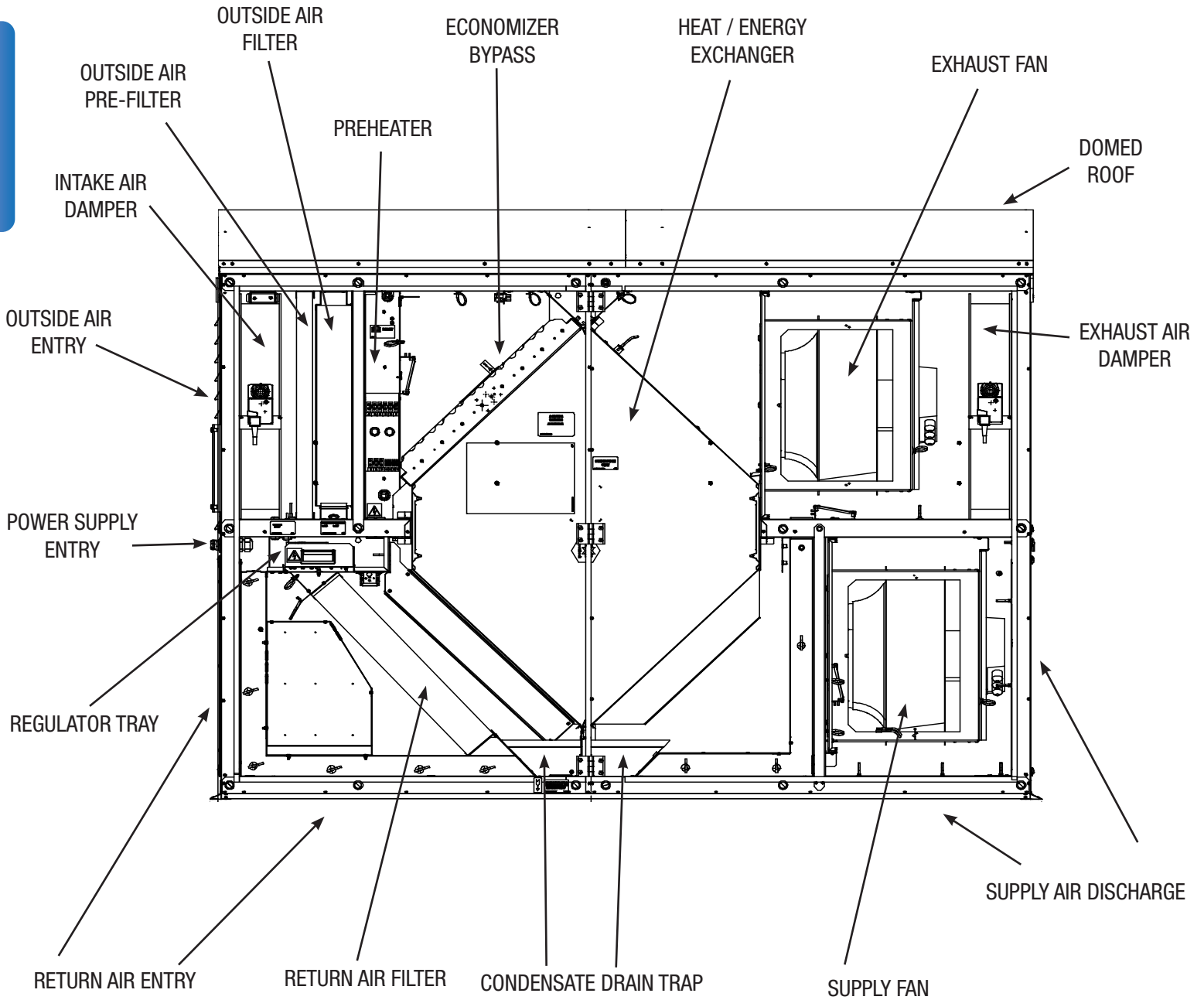

2. SPECIFICATIONS

2.2 MAIN COMPONENTS

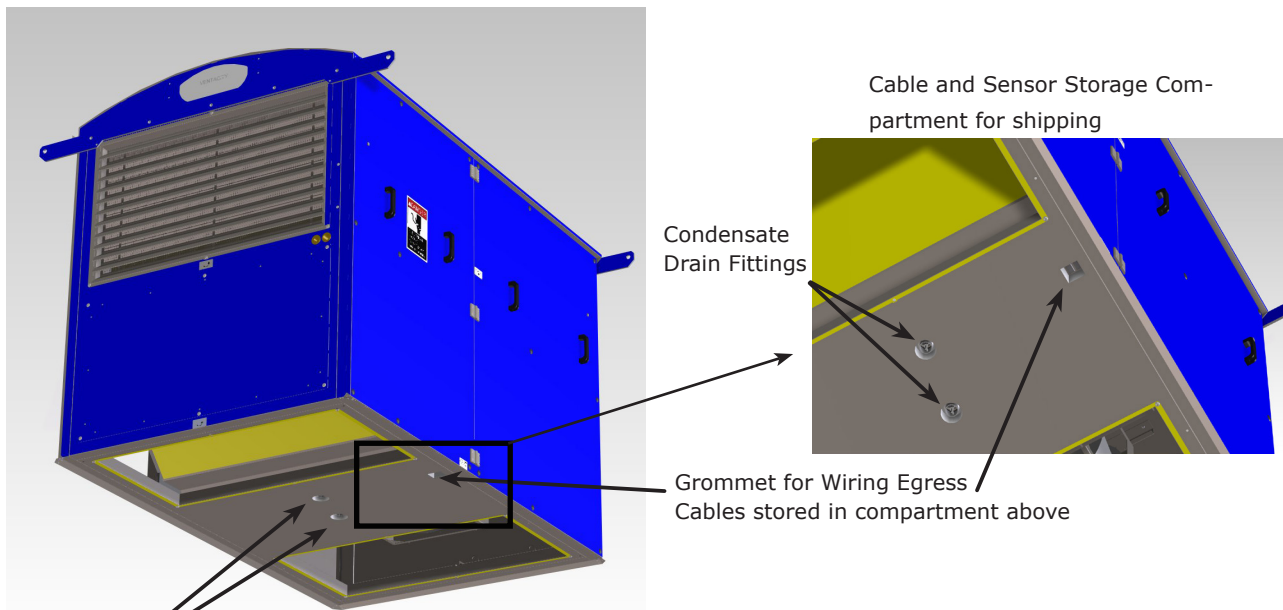
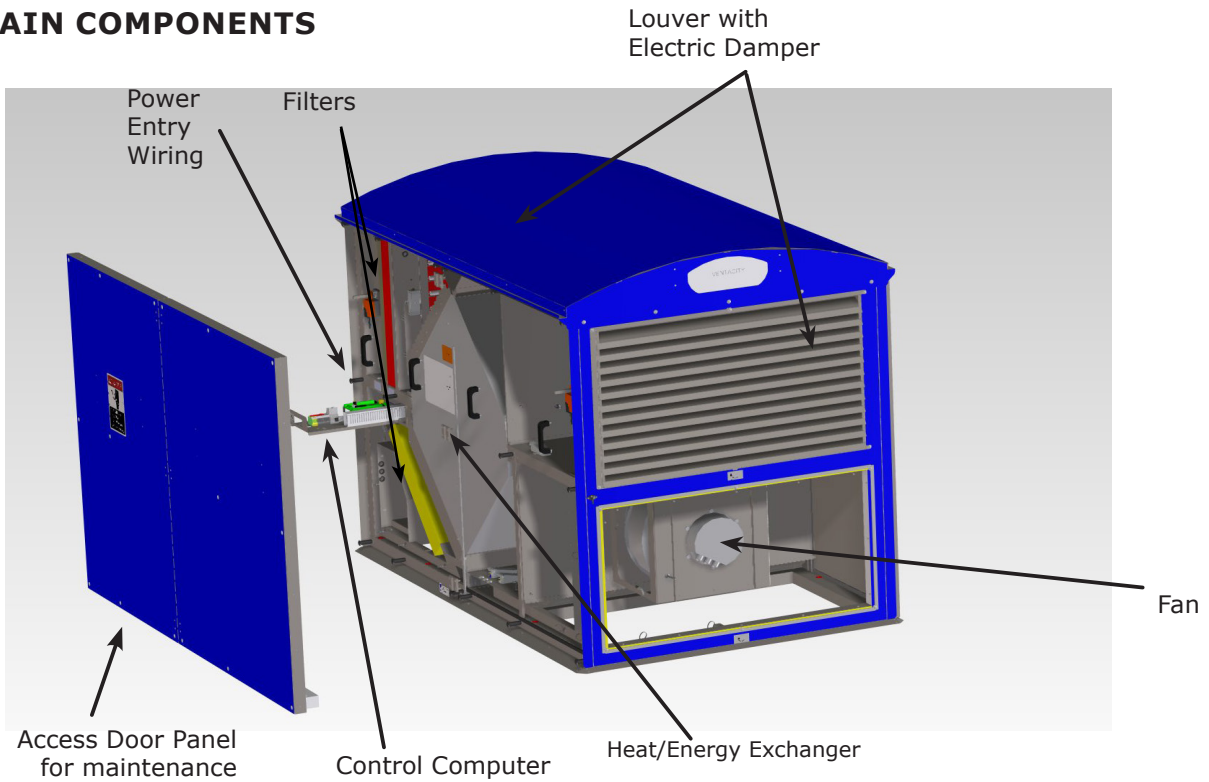

Condensate Drain Fittings



Control Panel



Communication Cable
RS-485 (131 ft)



Drain Trap with adapter

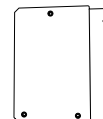

Power Disconnect Bracket

2. SPECIFICATIONS

2.3 GENERAL SPECIFICATIONS

VS3000RTh/e GENERAL SPECIFICATIONS

Flow Rate	750 - 3300 cfm / 1274 - 5607 m ³ /h	Increments: 250 cfm
Max. External Static Pressure	3.0 inch W.C. / 747 Pa	
Exchanger Efficiency (AHRI 1060)	HRV: 90% Sensible	ERV: 87% Sensible; 82% Latent; 85% Total
Ambient Temperature Conditions	-22° to 122° F / -30° to 50° C	
Max. Return Air Humidity	90%	
Dimensions (Shipping)	90.2" x 57.5" x 68.8" / 2.29 m x 1.46 m x 1.75 m (Shipping: 92" x 59" x 83")	
Weight (Shipping)	HRV: 1654 lbs / 750 kg (Shipping: 2,120 lbs) ERV: 1720 lbs / 780 kg (Shipping: 2,186 lbs)	
Dampers & Louvers	Integrated Automated Intake & Exhaust Dampers; Integrated Rain Protection Louvers	
Fans (EC, Variable Speed Control)	Backward Curved Aluminum Impeller; 1800 RPM; IP54	
Filters	Outside Air: 2" MERV8 & 4" MERV13 Return Air: 4" MERV8	
Preheater	Integrated Preheater for Frost Prevention	
Core Bypass	PID Bypass Damper for Temperature Control	
Insulation & Thermal Conductivity	2" Foam @ 0.022W/mK / 0.013 BTU/(hr ft °F); 0.8mm Galvanized Steel Casing	
Duct Connection	Outside & Exhaust: 26.51" x 46" Supply & Return: 24" x 46" (Down or Side Ducting)	
Operation Modes	CAV, DCV, VAV, BMS, Economizer (Freecooling)	
Certifications	TUV SUD (UL 1812, CSA 22.2 No. 113) Passive House: HRV (85%) & ERV (85%) FCC Class A	
Sensors	Temperature (10Kohm NTC Thermistors): Outside Air, Supply Air, Supply Duct, Return Air, Exhaust Air Pressure: OA and RA Filter Pressure Drop Pressure Differential at Supply Fan and Exhaust Fan (CAV) Pressure Differential of Supply to Atmosphere (VAV)	
Optional Accessories Provided by Ventacity	Duct CO2 Sensor (Can Recommend Room CO2 Sensor)	

> ELECTRICAL

Configuration	No PREHEATER		ENTIRE UNIT, 480V PREHEATER			ENTIRE UNIT, SINGLE VOLTAGE	
	CONTROLS + FANS		PREHEATER	CONTROLS + FANS		CONTROLS, FANS, & PREHEATER	
Circuit	208 VAC	240 VAC	480 VAC	208 VAC	240 VAC	208 VAC	240 VAC
Voltage	208 VAC	240 VAC	480 VAC	208 VAC	240 VAC	208 VAC	240 VAC
Phase	3Φ	3Φ	3Φ	3Φ	3Φ	3Φ	3Φ
Power Supply	3.84 kW	3.84 kW	21.7 kW	3.84 kW	3.84 kW	20.2 kW	25.6 kW
FLA – Max	10.7 A	9.3 A	26.1 A	10.7 A	9.3 A	56 A	61.6 A
MCA	11.9 A	10.3 A	32.7 A	11.9 A	10.3 A	68.6 A	75.7 A
MOP	15 A	15 A	30 A	15 A	15 A	70 A	70 A
De-Ice Preheater	-	-	21.7 kW	-	-	16.3 kW	21.7 kW
Max Power per Fan	1.9 kW (2.56 hp)						

> FAN VOLUME

Ext. Static Pressure (in. W.C.)	0.85	1	1.4	2.2	2.8	3	
Maximum Flow (CFM)	3,300	3,200	3,000	2,500	2,000	1,500	1,000
System Power (Watts)	3,984	4,007	3,928	3,753	3,456	2,873	2,267

> FAN POWER*

Airflow (CFM)	1,000	1,500	2,000	2,500	2,750	3,000	3,200
CFM/WATT (2 Fans)	2.1	2.0	1.6	1.3	1.2	1.1	1.0
System Power (Watts)	468	768	1,233	1,909	2,342	2,846	3,304

* at 1/2" water column

2. SPECIFICATIONS

2.4 FAN & CORE PERFORMANCE

VS3000RT @ 3000 CFM / 1.15" W.C.

f (Hz)	50	125	200	500	1200	2000	5000	8000	Total
Supply	46.0	56.8	51.7	51.9	54.0	49.6	42.8	38.7	68.7
Return (Extract)	42.0	44.5	44.0	37.0	35.0	30.5	21.0	14.6	57.4
Exhaust	42.2	58.2	48.6	54.6	51.9	45.7	42.0	37.9	65.8

> FAN OPERATING RANGE

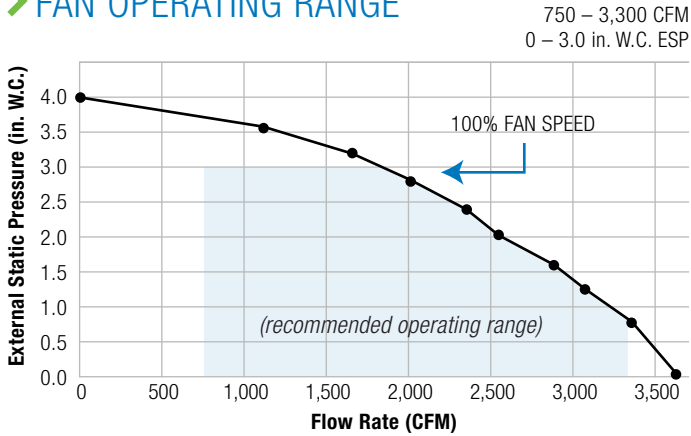

> HRV SENSIBLE EFFICIENCY

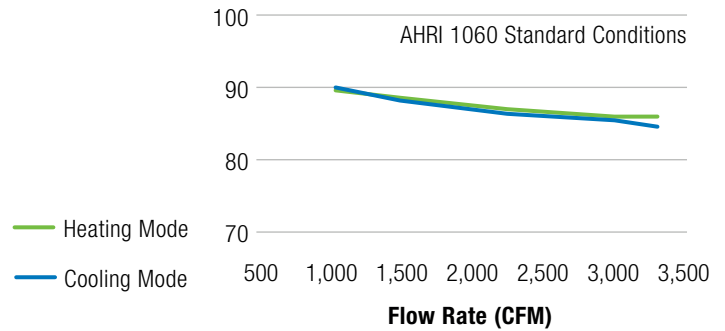

> ERV LATENT EFFICIENCY

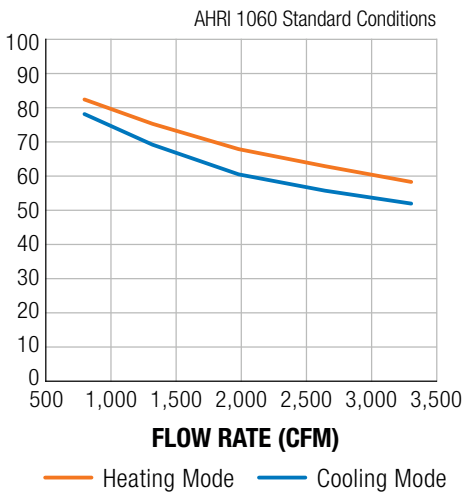

> ERV SENSIBLE EFFICIENCY

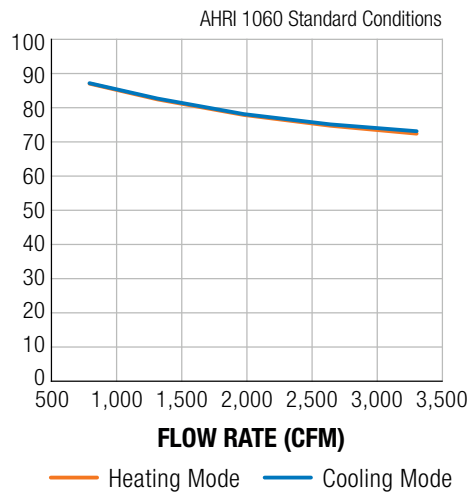

> ERV TOTAL EFFICIENCY

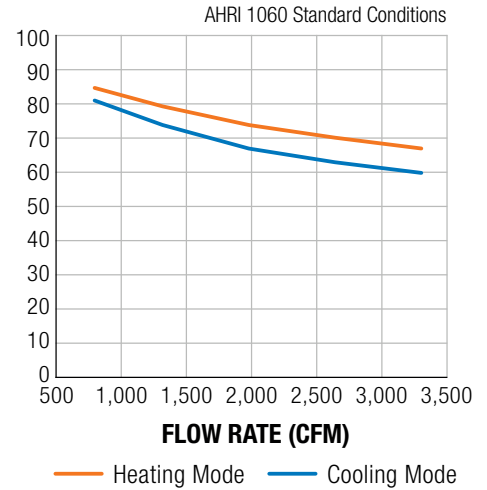

FILTER SPECIFICATIONS (Quantity: 2 of each)

Serial Number Range	Outside Air (OA) [MERV13]		Pre-Outside Air (Pre-OA) [MERV8]		Return Air (RA) [MERV8]	
	Part Number	Dimensions [inches]	Part Number	Dimensions [inches]	Part Number	Dimensions [inches]
3000057808 through CURRENT	1009131	23.375 x 23.375 x 3.75	1009124	26.375 x 25.625 x 1.75	1009125	25.00 x 25.625 x 3.75
#1 through 3000049650	1009123	26.375 x 25.625 x 3.75				

2. SPECIFICATIONS

2.5 DIMENSIONS (INCHES)

SPECIFICATIONS

SIDE VIEW

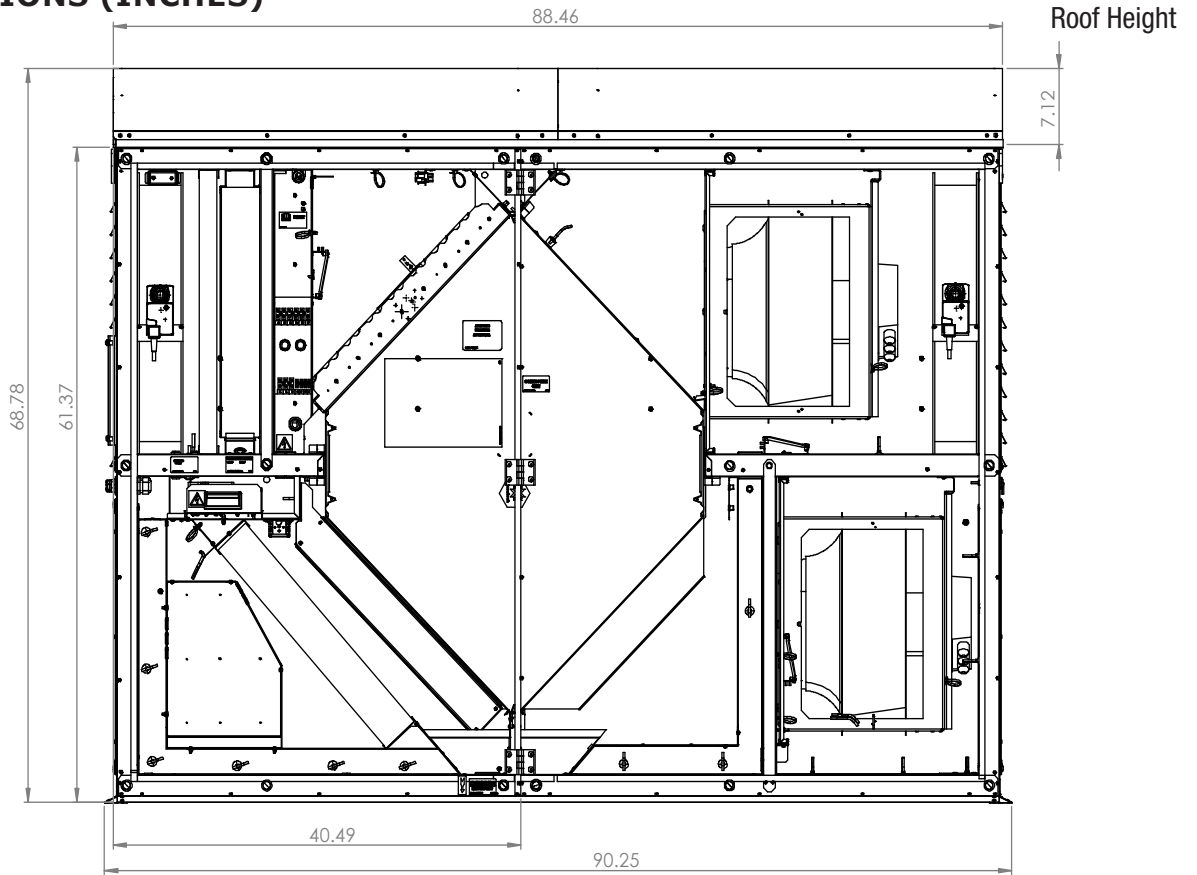

BOTTOM VIEW

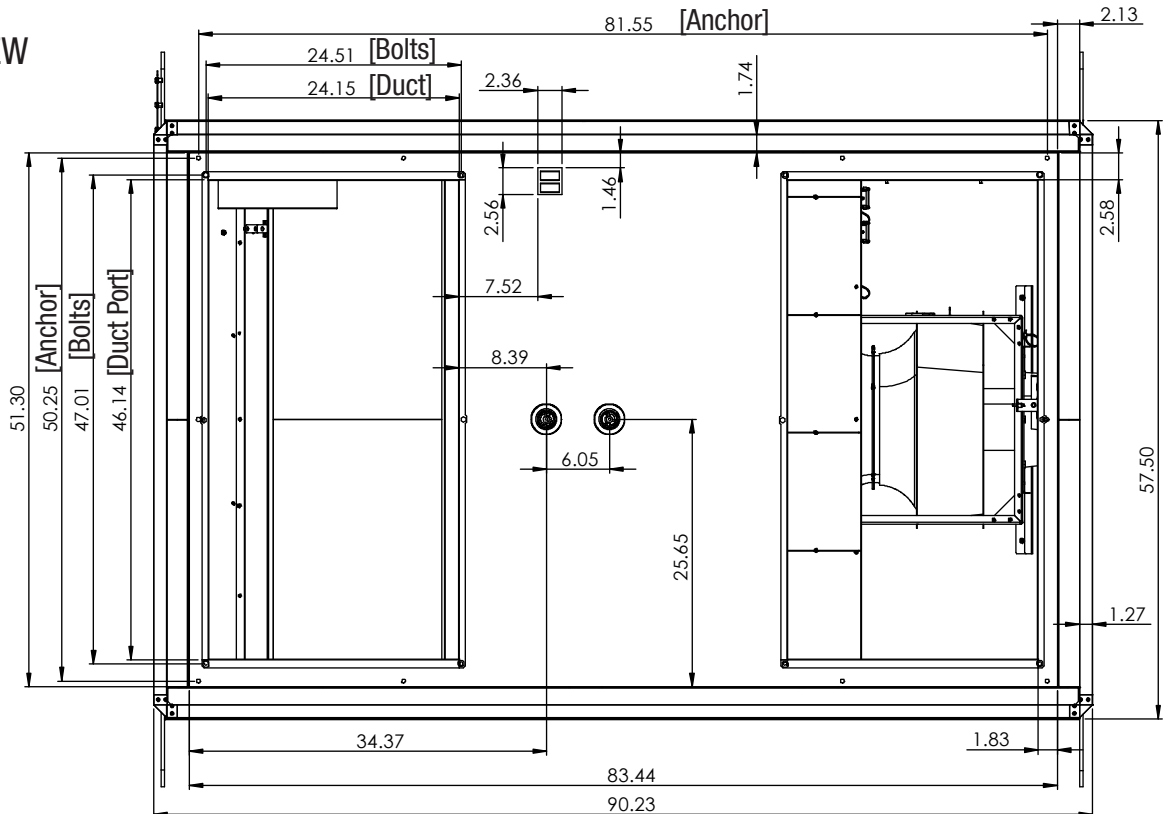

2. SPECIFICATIONS

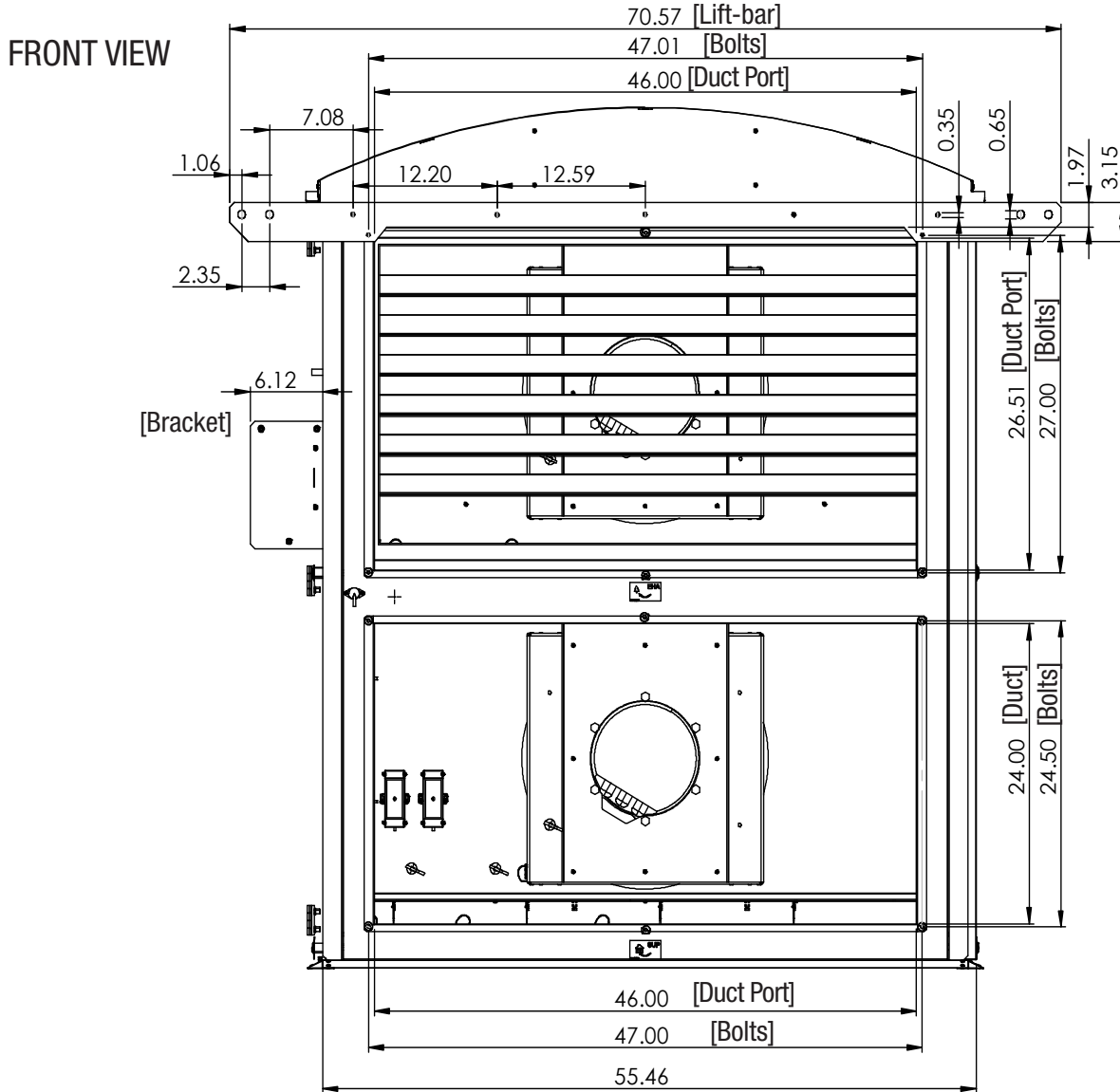

CONDENSATE DRAIN TRAPS

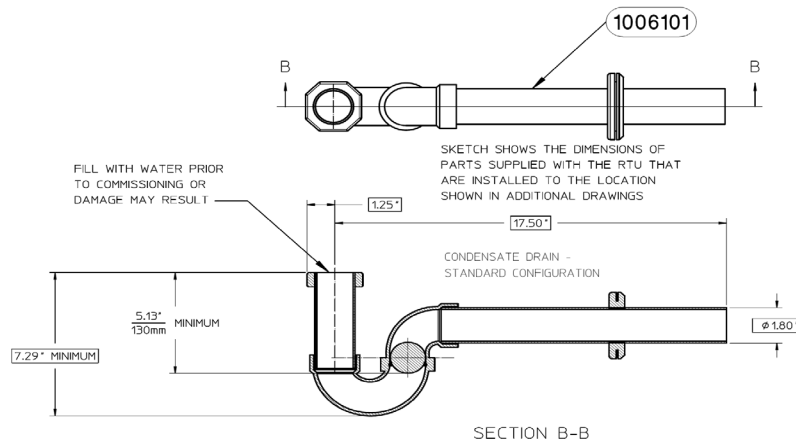

3. PLANNING

This section is designed to aid in the planning & design stage of both new and retrofit applications of the VS3000 RT HRV.

3.1 INFORMATION COLLECTION

3.1.1 Existing Curb - Retrofit/Replacement

Survey installation site to evaluate condition of existing curb and roof penetration.

Decide whether existing curb can be reused or repaired. If new curb is deemed necessary, see Section 3.1.2 for guidance in planning a new roof curb based on the VS3000's needs.

If existing curb is to be used, use the subsequent sections to determine whether to cap the preexisting curb or use a curb adapter.

Evaluate suitability of existing ducts

Ensure duct sizing is appropriate to support required ventilation using ASHRAE 62.1 *Ventilation for Acceptable Indoor Air Quality* and the operating space chart for the VS3000 (provided in Section 2).

Check existing ducts for corrosion, leakage, and sufficient insulation (minimum 1").

Plan any upgrades or replacements necessary to bring the air distribution system up to spec.

3.1.2 New Construction - No Existing System

Use ASHRAE 62.1 standards at minimum to calculate the necessary duct sizes/diameters. The minimum recommended sizes for primary ducting connected to the VS3000 RT are listed below.

Duct Type	Minimum dimension	Value
Circular	Inner diameter.	22 in
Rectangular	Cross-sect. area	380 in ²

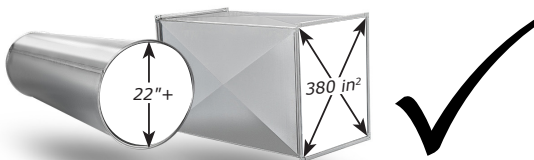

Duct insulation shall be 1" minimum on all sides to minimize efficiency loss through unwanted heat transfer.

Note: Certain applications may benefit from more insulation due to ambient conditions.

3.1.3 Power Requirement

Verify the electrical conditions from page 8 can be met at the installation site.

3.1.4 Clearances

The minimum clearance distances shown below must be met for safety and service purposes:

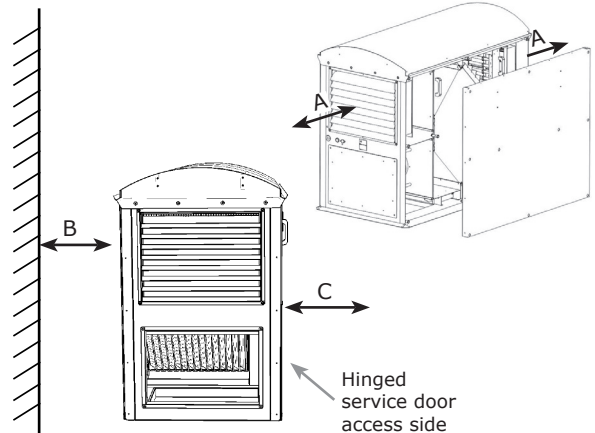

Model	A	B	C
VS3000 RT	24 in	36 in	48 in

3.1.5 Inlet/Outlet Protection

Climates where substantial buildup of snow, etc is possible may require shielding of intake and exhaust openings from excessive accumulation, which could result in impeded airflow and/or water ingress resulting in damage to the unit.

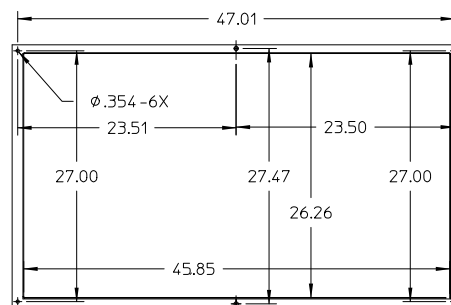
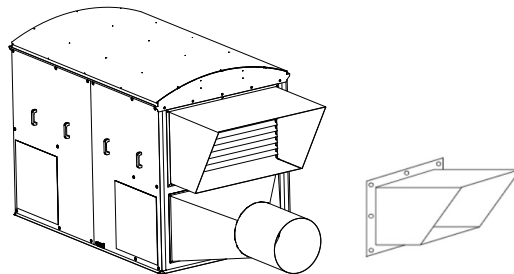

3.1.6 Plumbing

Certain mounting configurations may require the condensate drain to be routed into the building for drainage.

3. PLANNING

3.2 DOWN DUCTED OVERVIEW

The VS3000 RT is a new product, intended in many cases, to replace existing rooftop HVAC equipment. The downward facing duct connections are provided to easily facilitate the retrofitting of a DOAS unit to pre-existing RTU-based systems.

3.2.1 Mounting Styles



Mounted to curb

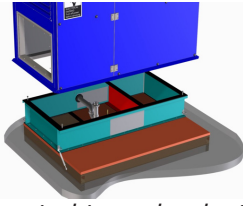

Mounted to curb adapter

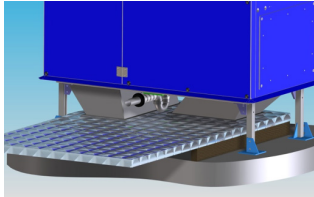

Mounted to pedestal

3.2.2 Duct Connection Options

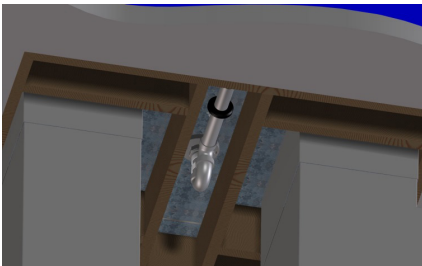

Ducts connected directly to bottom of HRV

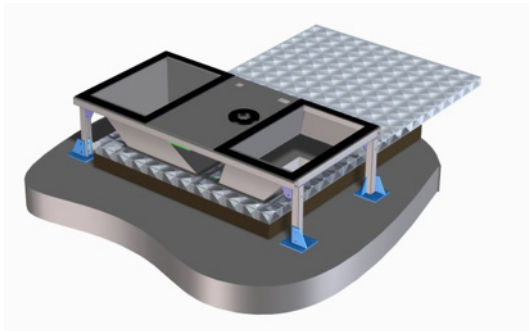

Ducts connected to curb, curb cap, curb adapter, or pedestal frame

3.3 SIDE DUCTED OVERVIEW

For applications where a bottom-ducted design is not practical, duct connections are also provided on either side of the HRV.

NOTE: The VS3000 RT must still be mounted on an appropriate structure in a side-ducted configuration to provide clearance and structural support where needed.

3.3.1 Mounting Options

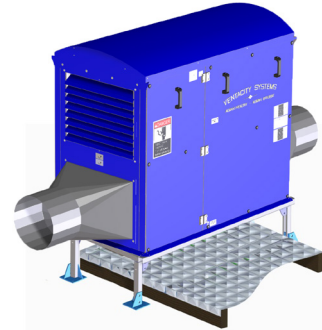

Mounted to pedestal

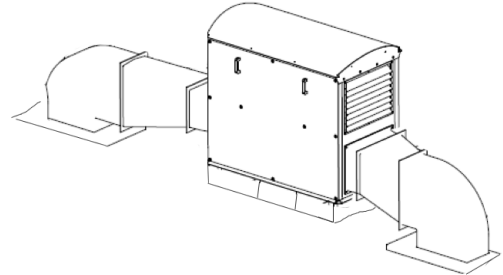

Mounted to stand

3.3.2 Side Duct Connection

Connecting ducts in a side-ducted configuration is accomplished by fastening ducts of appropriate size directly to the sides of the unit using (6) machine screws per duct.

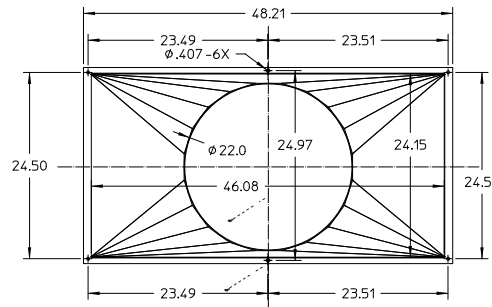
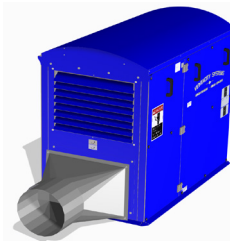

3. PLANNING

3.4 CONDENSATE DRAIN

For both bottom- and side-ducted configurations, a condensate drain must be assembled and connected beneath the unit in order to properly expel any moisture built up on the heat exchanger plates. Depending on mounting configuration, this may exit to the outdoor environment or into the building, where appropriate plumbing must be provided.

3.4.1 Access

Bottom ducted, Ducts attached to curb/adapter

When a curb/adapter is used, access to the condensate drain and bottom wire egress can be provided in two ways:

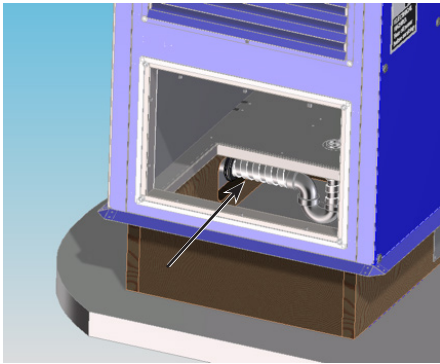

- Through the side plug, into the Room Air plenum

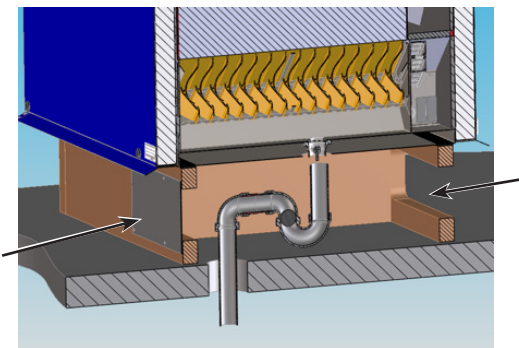

- Access panel in the side of curb adapter/curb

If the HRV's supporting structure is designed with two cross-members, access must be provided through a removable panel on the side of the curb or adapter.

Bottom ducted, Ducts attached directly to HRV

When ducts are attached directly to the HRV, access for servicing the condensate drain must be possible from inside the building.

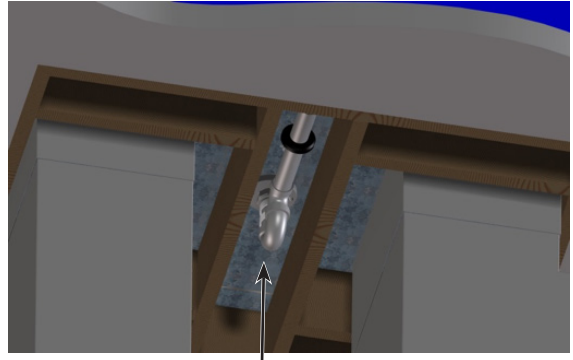

3.4.2 Frost Prevention

When installed in a climate where the temperature may reach freezing, measures must be taken to ensure ice does not form inside the condensate drain. Clogging of the drain can result in an overflow inside the unit, potentially causing damage to the unit itself and/or the connected ductwork.

Heating tape or heating cable in conjunction with a thermostatic control is often used to address this issue. It is the responsibility of the planner and installer to provide adequate frost prevention.

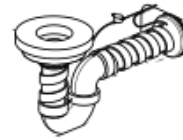

Heat tape installed on condensate drain

3.4.3 Clearance

The minimum clearance required for the condensate drain is 8.5" below the HRV. It is important when planning an installation of the VS3000 RT to account for this regardless of duct configuration.

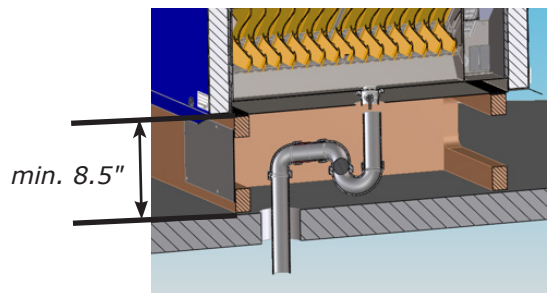

3. PLANNING

3.5 IN-DEPTH EXAMPLES AND CONSIDERATIONS

3.5.1 For All Installations

The 618 pound weight of the VS3000 RT is to be supported on the structural members within the base of the HRV. The structural members are set back from the visible perimeter of the HRV on the sides, as shown in the cross sections below.

This allows removal of the doors. The structural members on the ends lie near the perimeter and are under the end caps.

There is a full perimeter rain deflection skirt extending out from the support members.

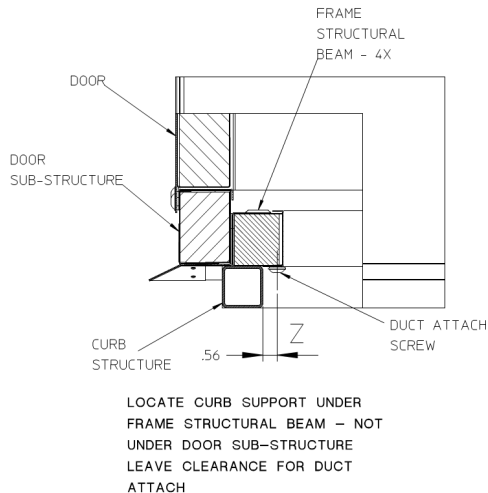
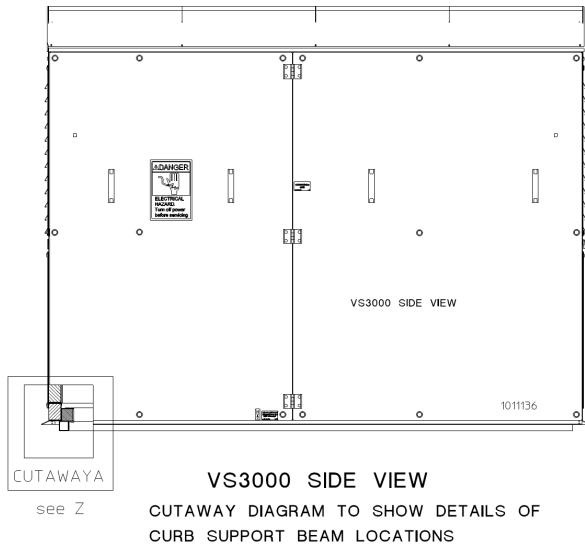

3.5.2 Simple Curb Construction

In order to precisely contact the structural elements of the HRV, follow the dimensions below for constructing a curb, curb adapter, pedestal mounting base, or stand.

The cross-member separates the RA plenum (left) and the SA plenum (right).

If down-ducted and ducts are not bolted directly to the HRV, service access to the condensate drain (and wiring egress) is possible through the RA side end plug.

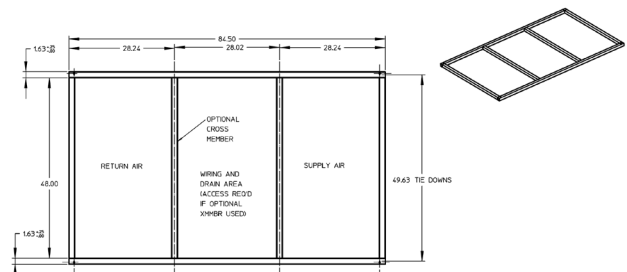

Note that the (6) mounting screw locations should be located at assembly, given normal fabrication tolerances.

In a side-ducted configuration, a stand must be fabricated following the same dimensions in order to create clearance for the condensate drain while properly supporting the weight of the unit.

The dimensions above apply to all mounting styles described in this manual. Further detailed dimensions of the VS3000 RT including the placement and size of duct openings can be found at www.Ventacity.com

3. PLANNING

3.5.3 Adapting to an Existing Curb

The preceding figure is drawn to resemble a simple roof curb designed for the VS3000 RT. If a curb already exists at the installation site, modifications must be made to provide adequate structural support for the HRV in the areas shown.

A common practice utilizing on-site fabrication to adapt the VS3000 RT onto an existing curb in lieu of a curb adapter involves the following:

- Add reinforcement beams as necessary to the existing curb
- Apply a sealed cap to the existing curb with duct openings to match the bottom of the VS3000 RT
- Seal and anchor both HRV and ducts in place

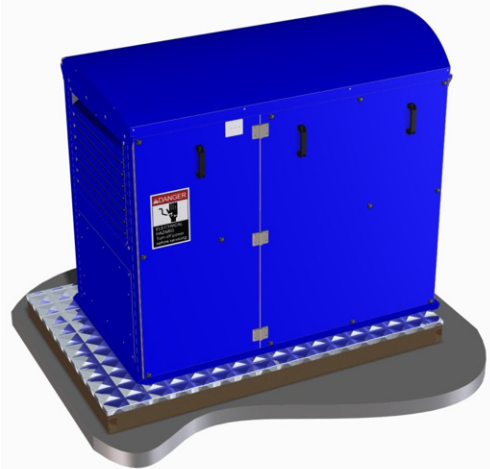

NOTE: To avoid water ingress and potential damage to the building, incorporate either a pitched surface into the cap for water runoff, or a raised flange contacting the bottom of the HRV.

3.5.4 Ordering a Third Party Curb Adapter

Functionally similar to a capped curb, a curb adapter sourced from a third party provides a more "plug-and-play" installation process. See section 3.4 - 3.5 for details on condensate drain requirements and cross-members.

The adapter is specified by sending the builder the locations of the duct openings of both the existing curb and the new VS3000 RT.

Builders can also design to model number references of the demolished unit and the VS3000 RT. Consult Ventacity Systems, Inc. for a referral to a curb adapter supplier familiar with the VS3000.

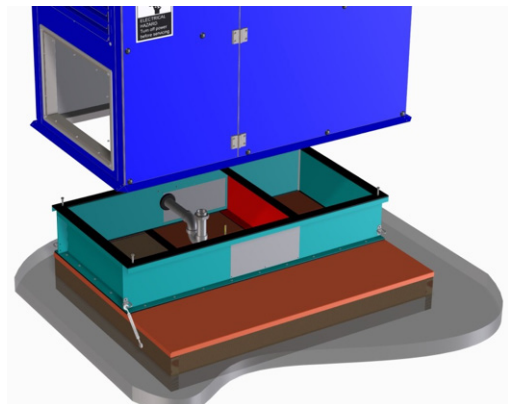

VS3000 RT mounting to a curb adapter

3.5.5 Generic Pedestal Mounting Frames

In certain situations, none of the previously outlined mounting methods/styles are viable options. Some circumstances that may lead to this scenario include:

- Curb structure not rated for load of VS3000 RT ('outrigger' supports needed)
- Curb smaller than footprint of the HRV
- Additional height desired to keep unit clear of heavy snow accumulation

A number of configurations are possible with this design to suit the needs of a given installation site. The basic permutations are outlined here for reference; if you require additional assistance in designing a support structure for your VS3000 RT, contact Ventacity Systems, Inc.

NOTE: The load bearing structure of these designs can be used in a side-ducted configuration as a stand to provide the necessary clearance for the condensate drain.

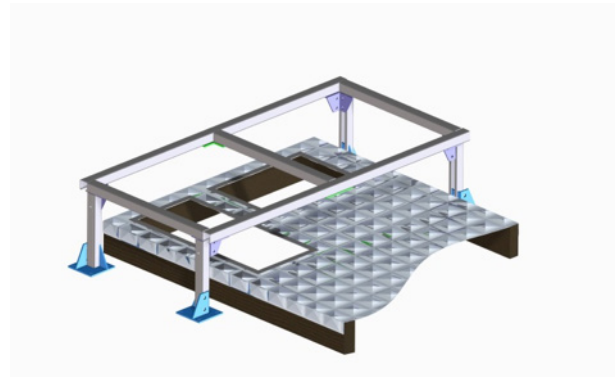

Example Pedestal Frame

3. PLANNING

Net-Fit Flex Frame

This design is as long and as wide as the structural members within the HRV, and is likely the most appropriate design to create the necessary condensate drain clearance in a side-ducted design.

A design of this type will span over the entire curb and allow for adequate distance between the HRV and curb cap to fit well-designed transition ducts.

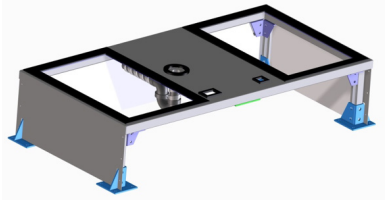

Net-Fit Flex Frame

X-Flex Frame and Y-Flex Frame

These classifications of flex frame allow for spanning curbs whose outermost dimensions are larger in *either* length or width, respectively.

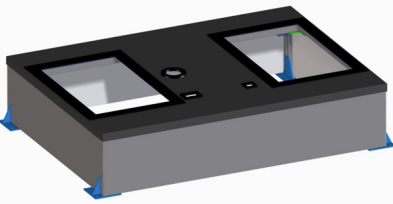

X-Flex Frame Pedestal

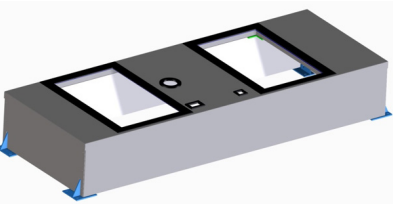

Y-Flex Frame Pedestal

X-Y Flex Frame

An X-Y Flex Frame is the classification given to a pedestal in which the outer dimensions of the existing curb are larger in both directions than the base of the VS3000 RT.

This is also appropriate for use where the span between load-bearing segments of the roof structure is greater than 65" x 95".

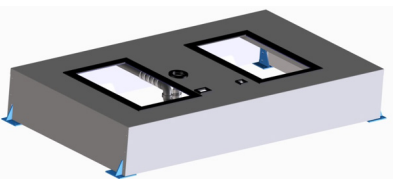

XY-Flex Frame Pedestal

3.5.6 Side-ducted configuration

In the event a bottom-ducted configuration is not feasible, the VS3000 RT can be ducted out the ends of the unit.

When implementing a side-ducted configuration, extra attention should be paid to the possibility of snow accumulating on top of the ducts and obstructing the unit's inlet & outlet.

A side ducted configuration may be ideal if the supply and return ducts exit the building through separated penetrations in the roof or wall.

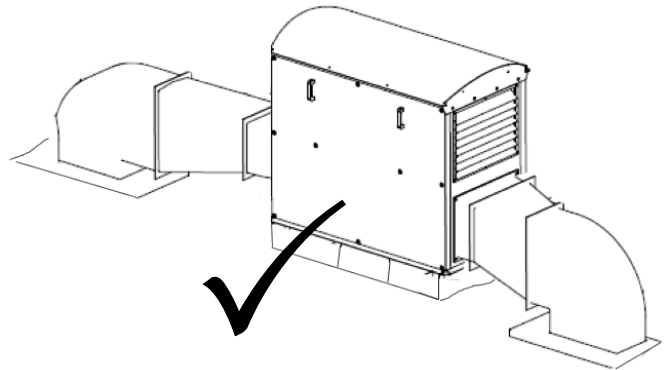

Side-ducting *IS NOT* recommended for applications with a single roof penetration for both supply air and room air ducts. These configurations are nearly always better suited for use with a bottom-ducted configuration.

The resulting ductwork in this scenario can make servicing the unit significantly more difficult and lowers efficiency through undesirable heat transfer and increased static pressure in the system from unnecessary tight elbows.

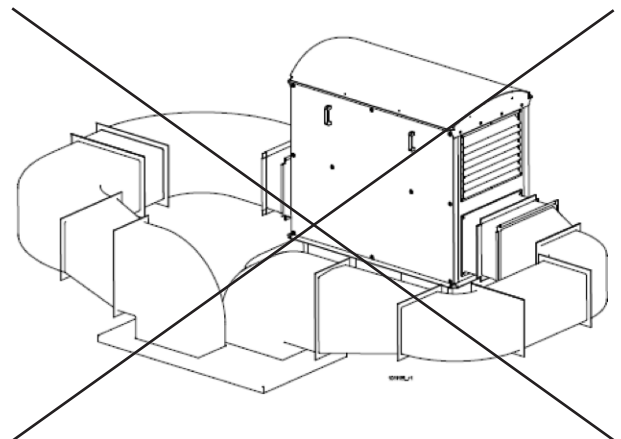

4. INSTALLATION

4.1 ROOF & BUILDING PREP

- These procedures can be completed in preparation for installing of the HRV.
- Prepare electrical hookup line as specified by engineering firm.
- In retrofit / upgrade applications, remove existing RTU.
- The use of a sealant such as VOC-free mastic or caulk at the HRV-Curb and Curb-Duct interfaces is recommended to prevent any air leakage and optimize performance.
- The use of gasket material and exterior rated caulking between the HRV and the curb is recommended to prevent any water leakage.

4.1.1 Direct / Simple Curb

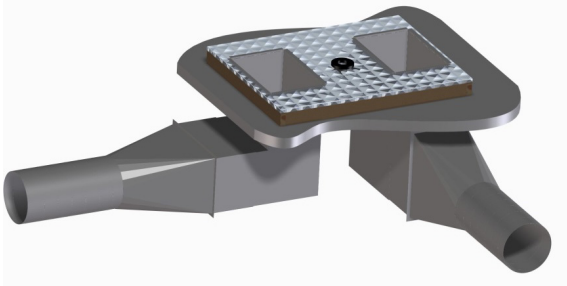

- Construct new curb, or cap existing curb as per installation plans.
- If necessary, fabricate or use purchased duct adapters to connect building duct system to cap/curb (or ready to bolt to HRV).

4.1.2 Curb Adapter

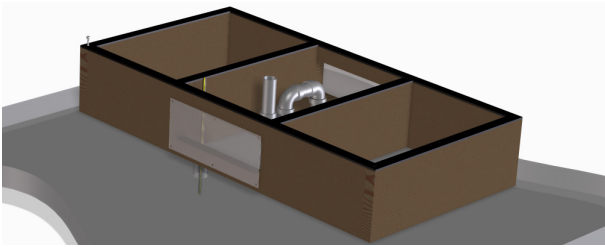

- Install application-specific curb adapter to curb.
- Attach ducts from inside building to curb adapter ensuring connections are airtight.

4.1.3 Pedestal Mount

- Construct and securely attach curb cap if necessary/applicable.
- Attach ducts from building to curb cap.

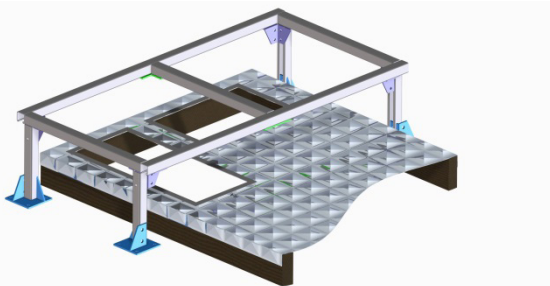

- Fabricate pedestal mount from unistrut on site according to installation plans and anchor in place.
- Construct and install transition ducts between pedestal and HRV

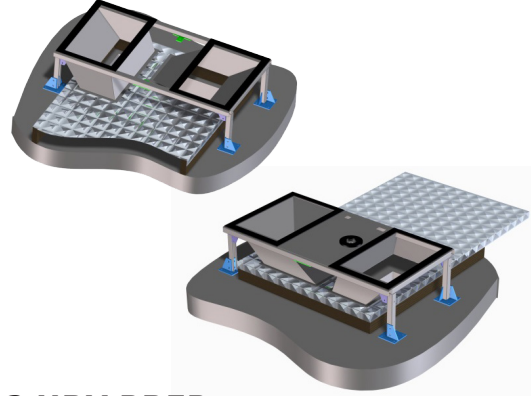

4.2 HRV PREP

Upon delivery, check the product packaging for possible damage. If the packaging is damaged, notify the carrier. If the claim is not made in due time, any claims thereafter cannot be considered.

Check whether the product model corresponds to your order. If the product model does not correspond, do not unpack it and contact the supplier immediately.

4.2.1 Remove Liftbar and Crate from Unit

- Remove the liftbars from the top of the unit indicated in the figure below. Place aside.
- Remove the phillips screws securing the top planks then remove the planks.
- Remove the crate boards by removing the phillips screws securing crate boards as indicated in the figure below.

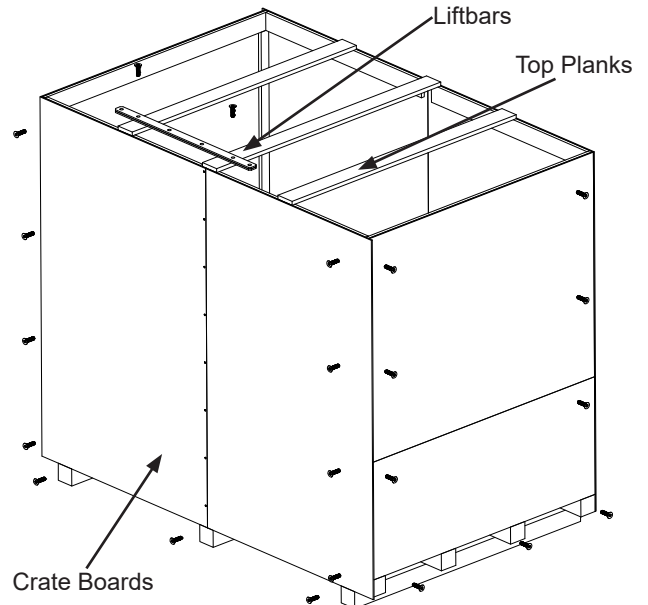

4. INSTALLATION

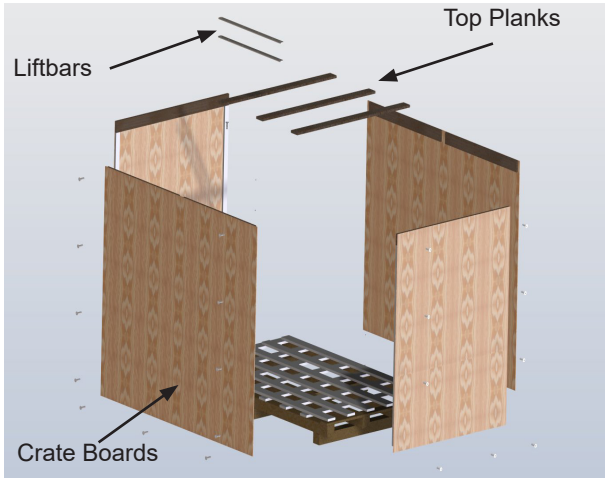

READ CAREFULLY!

If the HRV unit was exposed to temperatures lower than 32 °F (0 °C) during transport, keep it unpacked for at least 2 hours at room temperature before connecting it. This ensures that there is no difference between temperatures inside and outside the unit.

If the unit is not unpacked immediately after its receipt, it must be stored in a dry place at temperatures from 41 to 95 °F.

4.2.2 Unpack and Verify

- Open the access door by removing the 8 bolts as shown in Figure.
- With the service access door open, remove and inspect the components packaged inside the HRV. Notify Ventacity Systems immediately in the event a component is damaged or missing.

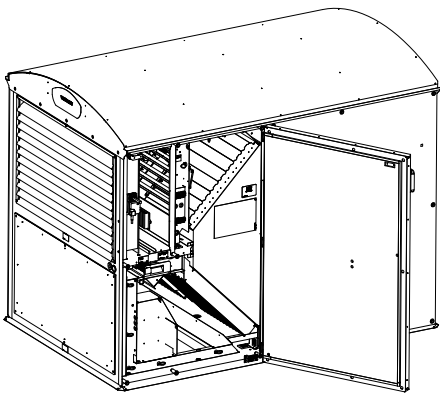

READ CAREFULLY!

The side door does not need to be fully removed to access the included accessories. If either side cover is removed, the earth ground strap must be disconnected first.

It is not recommended to remove more than one side cover at a time.

4.2.3 Removal from Pallet

The VS3000 RT is anchored to the pallet for protection during shipping. To remove the HRV from the pallet:

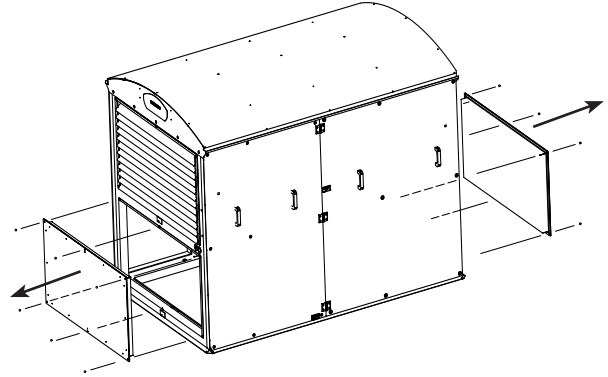

- Remove both end plugs

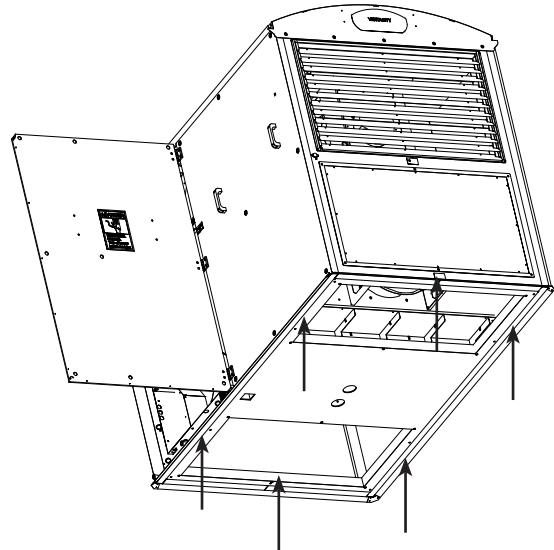

- Remove the fasteners at above locations.

READ CAREFULLY!

Screws used for anchoring the unit to the shipping pallet may be used to anchor the HRV to a wood base frame on the roof.

- After unpacking the unit, check its condition and condition of all its components. In case of doubt contact the supplier.
- Never use a damaged unit.
- Use caution when removing or installing screws with power tools, to avoid stripping or cross-threading fasteners.

4. INSTALLATION

4.2.4 Duct Plug Configuration

- For units to be installed in a side-ducted configuration, the duct plugs must be reinstalled on the bottom duct apertures after the unit is lifted from the pallet and before the unit is mounted on its stand.

Note: Gaining access to the fasteners on the plugs will in most cases require lifting of the HRV. The use of a medium strength thread locking product may be used on these (12) fasteners to minimize the possibility of a plug coming loose over time.

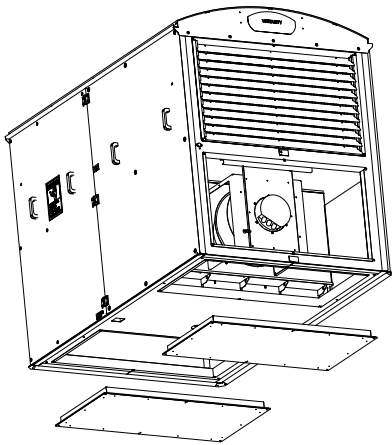

- On both EA and SA plenums, reposition the temperature sensor bracket as shown, making sure not to damage the sensor or its cable.

Configured for bottom-ducting
(As shipped)

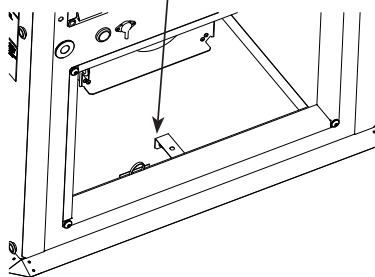

Configured for side-ducting

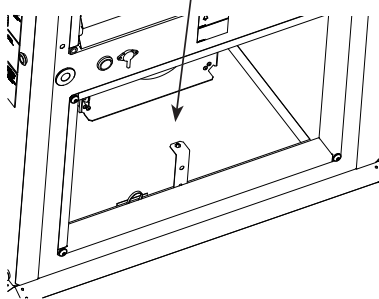

4.3 PHYSICAL INSTALLATION

4.3.1 Placement

- Connect lift bars to crane, forklift, etc.
- Lift HRV off pallet and lower onto prepared mounting location.

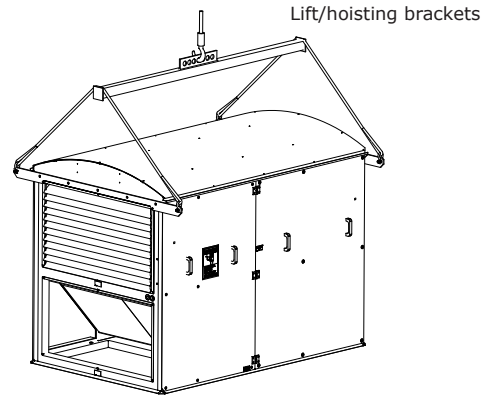

Note: Do not lower the HRV onto a flat surface. This will result in damage to the drip rail. Supports must be correctly aligned with the unit's structure underneath.

4.3.2 Duct Attachment

- Connect ducts to respective apertures using the existing threaded inserts as anchor points.
- Do not use self-tapping screws, etc.
- The use of a sealant between duct and HRV such as VOC-free mastic is recommended to prevent any air leakage and optimize performance.

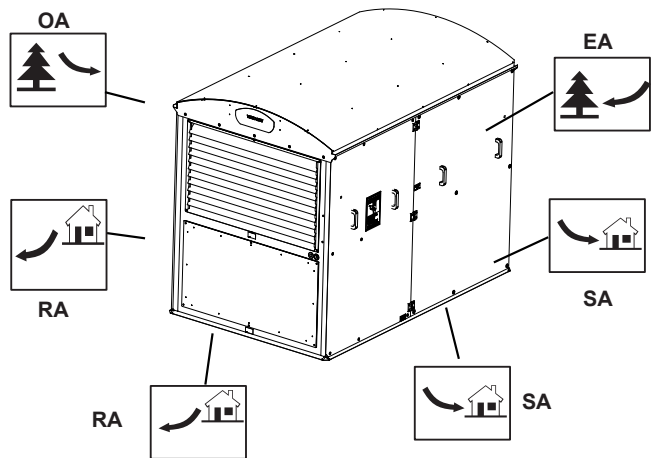

	Outside Air - Fresh air entering the HRV
	Room Air - Extracted from inside the building
	Supply Air - Fresh, heat-recovered air entering the building
	Exhaust Air - Unwanted air from building after heat recovery

INSTALLATION

4. INSTALLATION

🔍 READ CAREFULLY!

- The connected ducts must have the same cross-sectional area as the unit's inlets and outlets. Using a smaller diameter may decrease the unit's efficiency or shorten the unit's life.
- Connect the inlets and outlets (rectangular/circular hole). The use of flexible joints is recommended to prevent vibration.

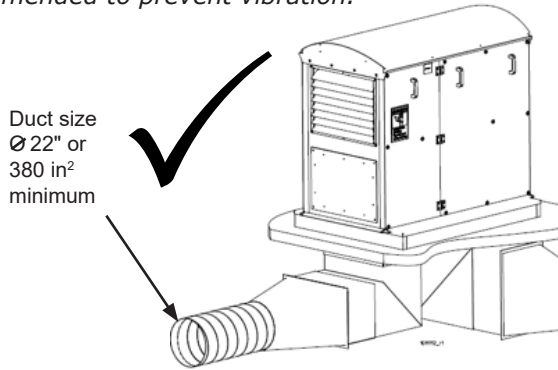

4.3.3 Condensate Drain

- Assemble the supplied condensate drain trap and attach to the indicated connection on the underside of the unit.
- Depending on the installation site climate, it may be necessary to install heat tape/heating cable on the drain trap to prevent freezing during colder weather.
- Route the condensate drain exit according to the planner's design.

🔧 YOU WILL NEED

- 1 drain trap
- PVC discharge pipe
- Discharge pipe sealing
- Adapter pipes (4pcs)

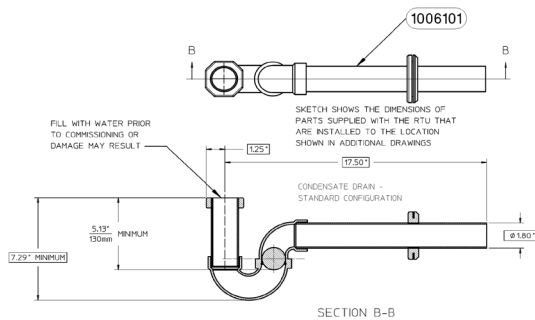

- The outlet of the condensation tray is located under the HRV unit.
- Connect the drain between the outlet and the pipe or hose leading to the drain.

⚠️ ATTENTION!

Before putting the unit into operation, fill the trap with water! Otherwise there is a risk of flooding and damage to the unit.

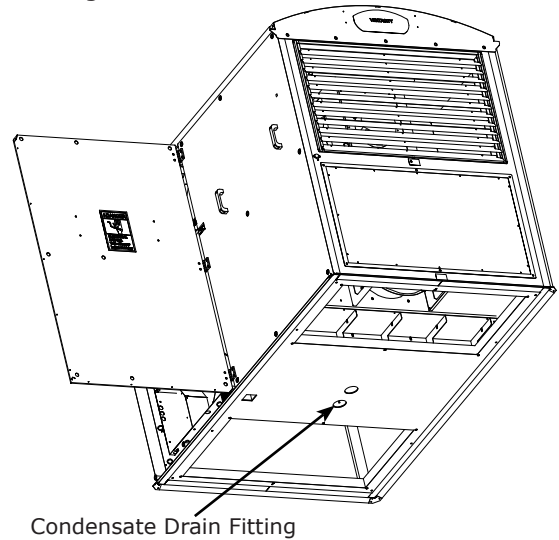

4.3.4 Securing the Unit

- The unit must be securely attached to its base such that it cannot move accidentally.
- In accordance with the engineer's plans, attach the unit to its mounting base at all four corners.
- Add seismic anchors where required by local building code

The anchoring points must be set out according to the following drilling template.

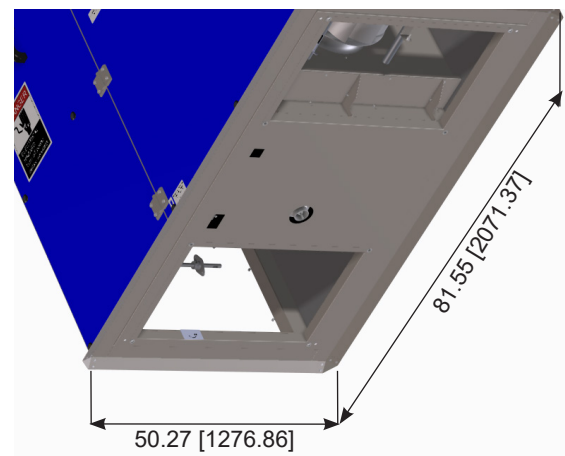

All dimensions are in **inches [mm]**.

4. INSTALLATION

4.4 ELECTRICAL INSTALLATION

⚠ ATTENTION!

- Before beginning repair or modification of the HRV unit, make sure the main power switch is off!
- The HRV unit's wiring must correspond to a layout designed by a professional electrician. The wiring must be done by a person authorized to perform electrical installations. It is necessary to follow all instructions in this manual and to comply with local laws and regulations.
- The wiring diagrams depicted on the unit take precedence over diagrams in this manual! Before connecting the wiring, make sure that terminal indications match the diagram. If in doubt, do not connect the unit, and contact the supplier!
- If the unit is connected to anything other than the original control system, contact the control system supplier for the wiring diagram of individual controls.
- The unit must be connected to the mains using a heat-protected, rigid, insulated cable with a cross-section that meets local regulations.
- To maintain electrical protection, all cables must fit in the holes on the sides of the control unit casing.
- Any changes or modifications to the internal wiring of the unit are prohibited and will void the warranty!
- The unit's correct operation can be guaranteed only if original accessories are used.
- If it is necessary to install a sensor or control component in the unit or on its casing, consult beforehand with the unit manufacturer or representative.

Main Power Disconnect Panel (Customer Furnished) Diagram of Preheater Connection (208 / 480 Jumpers)

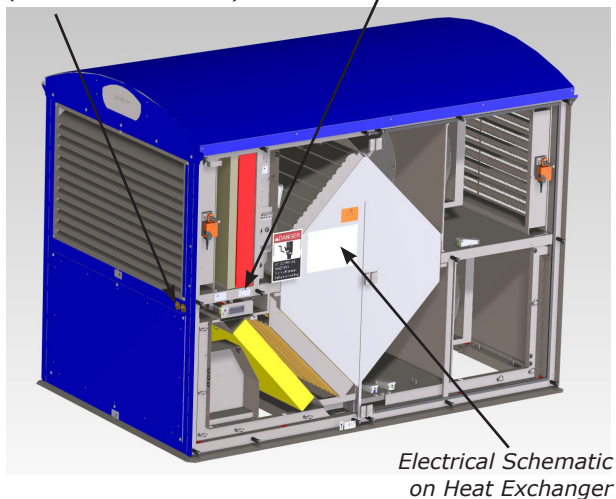

4.4.1 SUPPLY WIRING

Two sets of supply leads are provided protruding from the wiring egress ports for connection to power disconnect panels (Preheater panel and Controls/Fans panel) as depicted in the below diagrams. Additionally, a bracket is provided to mount the Controls/Fans disconnect panel on the VS3000 RT.

Electrical equipment shall be firmly secured to the surface on which it is mounted. Each disconnecting means shall be legibly marked to indicate its purpose unless located and arranged so the purpose is evident. The marking shall be of sufficient durability to withstand the environment involved.

⚠ ATTENTION!

Minimum size of the protective grounding cable must comply with local safety regulations regarding heavy current lead through a device's protective grounding cable.

⚙ TECHNICAL DATA

Wiring parameters can be found on the label installed on the heat exchanger.

SUPPLY WIRING: 208VAC Service

208VAC, 3Ø OCPD
50A

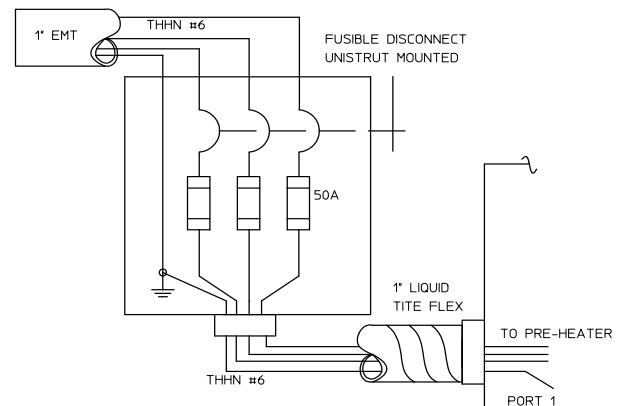

208VAC, 3Ø OCPD
15A

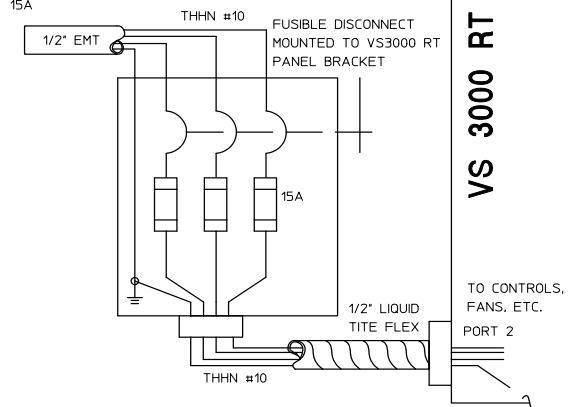

4. INSTALLATION

SUPPLY WIRING: 208/480VAC Service

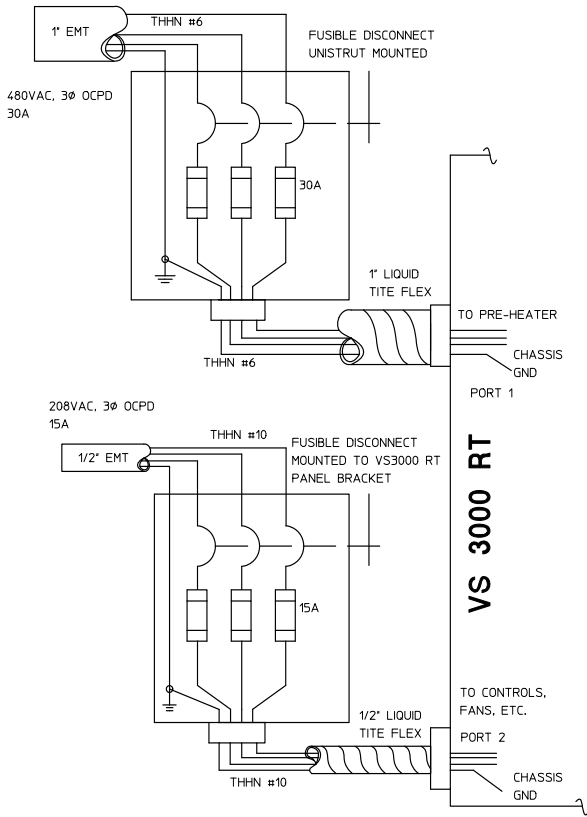

SUPPLY WIRING: 480VAC Service

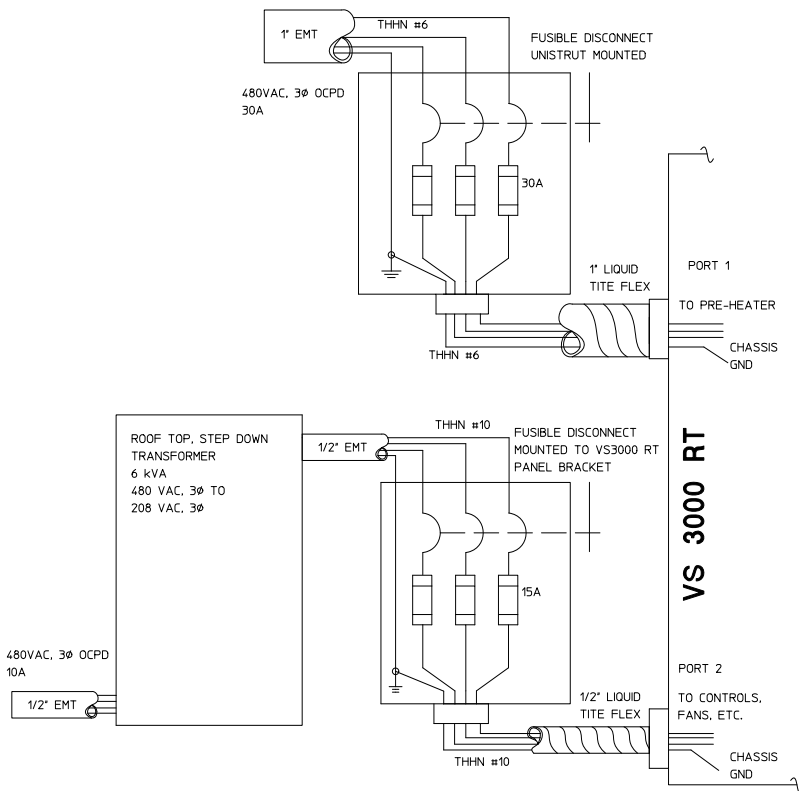

⚠ ATTENTION!

After the unit is switched off from the user interface panel, wait 150 seconds before disconnecting the unit from the power supply (required for full closure of dampers)!

All phases of the electric power supply must be connected through the corresponding type of disconnect box. The distance between disconnected contacts must be greater than 0.12 in [3 mm].

The disconnecting means shall be installed at a readily accessible location.

The Preheater disconnect panel shall be installed on unistrut in close proximity to the unit.

Each disconnect shall be permanently marked to identify it as a service disconnect.

Each disconnect shall be marked to indicate the load served.

Jumper Configuration for 208V or 208/480V

Jumpers located on control computer drawer must be configured correctly for proper functionality of preheater.

PREHEATER WIRING DIAGRAM

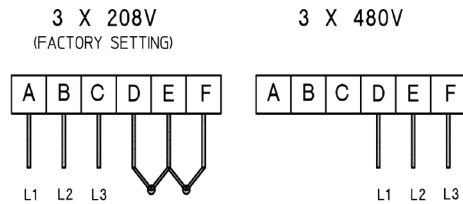

For additional electrical requirements and performance, see Specifications section.

4. INSTALLATION

READ CAREFULLY!

- The wiring schematic is located inside the main enclosure cover (connection side), on the heat exchanger.
- Each accessory must be connected with a supplied cable, or a cable that meets the specifications of all individual components.

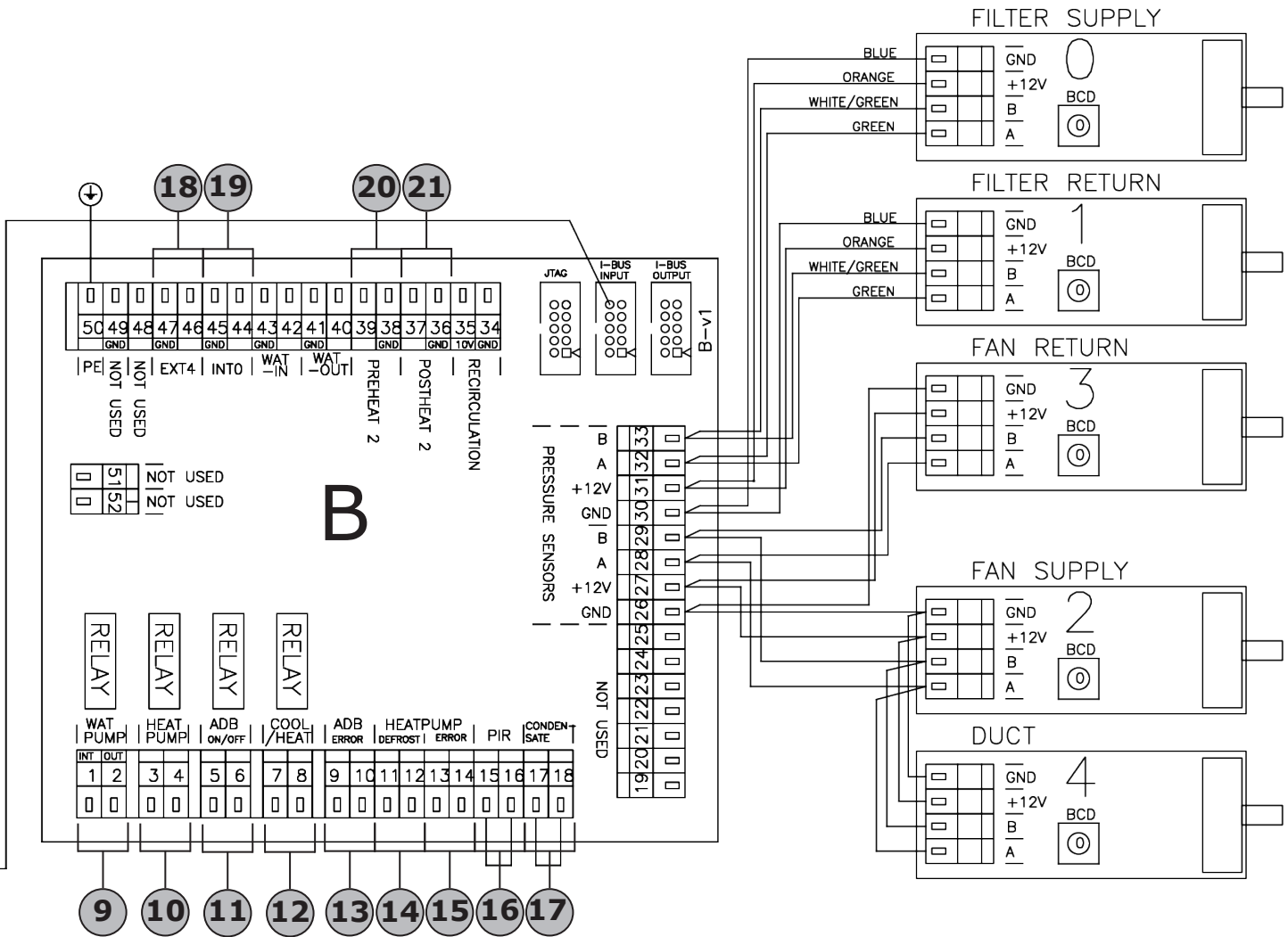

9	B (1-2)		WATER PUMP (1 - Int, 2 - Lout)
10	B (3-4)	Out	HEAT PUMP CONTROL settable (- ON/OFF)
11	B (5-6)	OUT	ADIABATIC MODULE (- ON/OFF)
12	B (7-8)	Out	COOL / HEAT settable (CO = NC/NO - DX = settable)
13	B (9-10)	IN	ADIABATIC MODULE ERROR (NO)
14	B (11-12)	In	HEAT PUMP DEFROST settable (NC/NO)
15	B (13-14)	In	HEAT PUMP ERROR settable (NC/NO)
16	B (15-16)	In	PIR (NC)
17	B (17-18)	In	CONDENSATE OVERFLOW (NC)
18	B (46-47)	In	EXTERNAL TEMPERATURE SENSOR (external postheater)
19	B (44-45)	In	EXTERNAL TEMPERATURE SENSOR (adiabatic module)
20	B (38-39)	Out	EXTERNAL PREHEATER (Water= 0-10V)
21	B (36-37)	Out	EXTERNAL POSTHEATER (Water= 0-10V)

INSTALLATION

4. INSTALLATION

4.4.2A BOOST BUTTON (Module A)

- Low voltage switching contact: maximum possible contact load 12 V, 0.4 A.
- Cable: two conductors with a minimum cross-section of 20 AWG [0.5 mm²] and maximum length of 164 ft [50 m].
- The contact is normally open. Unit reacts to rising edge of signal. Boost button can activate but not deactivate boost mode.

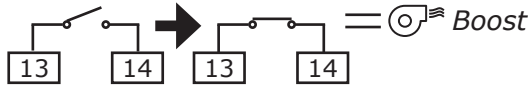

4.2.2B FIRE CONTACT (Module A)

- Low voltage switching contact: maximum possible contact load 12 V, 0.4 A.
- Cable: two conductors with a minimum cross-section of 20 AWG [0.5 mm²] and maximum length of 164 ft [50 m].
- The contact is normally closed. When disconnected, the HRV unit operates according to the pre-set output.

The required output can be set in the service menu. See page 32.

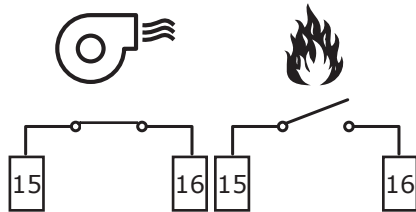

4.4.2C EXTERNAL CONTROL (Module A)

- Low voltage switching contact: maximum possible contact load 12 V, 0.4 A.
- Cable: two conductors with a minimum cross-section of 20 AWG [0.5 mm²] and maximum length of 164 ft [50 m].
- The unit responds to the rising/falling edge of the signal (opening / closing)
- Transition from open to closed turns unit on
- Transition from closed to open turns unit off

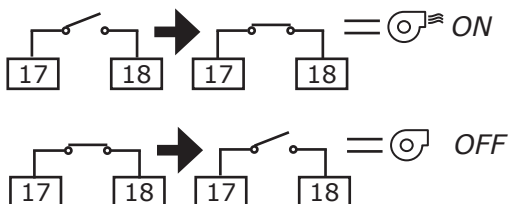

4.4.2D ROOM TEMPERATURE SENSOR (Module A)

- Low voltage input: 10k NTC thermistor
- Cable: Two conductors with a minimum cross-section of 20 AWG [0.5 mm²] and maximum length of 164 ft [50 m].
- Use: Control HRV set point temperature to ambient temperature in room.

Configure from main menu. See page 31 for details

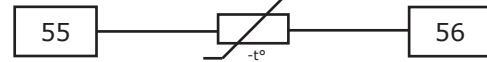

4.4.2E INDOOR AIR QUALITY SENSOR

- Low voltage input: 0-10V DC
- Cable: two conductors with a minimum cross-section of 20 AWG [0.5 mm²] and maximum length of 164 ft [50 m].
- Any 0-10V sensor supported. Advanced configuration available for CO₂, RH, VOC.

Configure from service menu. See page 31 for details

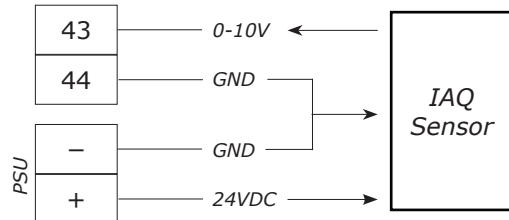

4.4.2F PIR/OCCUPANCY SENSOR (Module B)

- Low voltage switching contact: maximum possible contact load 12 V, 0.4 A.
- Cable: two conductors with a minimum cross-section of 20 AWG [0.5 mm²] and maximum length of 164 ft [50 m].
- The contact is normally closed. When opened, the HRV unit operates according to the pre-set ventilation output.

Configure from service menu. See page 33 for details

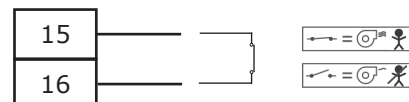

4. INSTALLATION

4.4.3 CONTROL PANEL CONNECTION

To activate the unit, it is necessary to connect the control panel and the unit using the communication cable (data cable).

- Loosen the screw on the bottom of the control panel.
- Open the control panel case.
- Connect the control cable conductors as shown below.
- Attach the user interface panel to the wall.
- Close and tighten the control panel case.

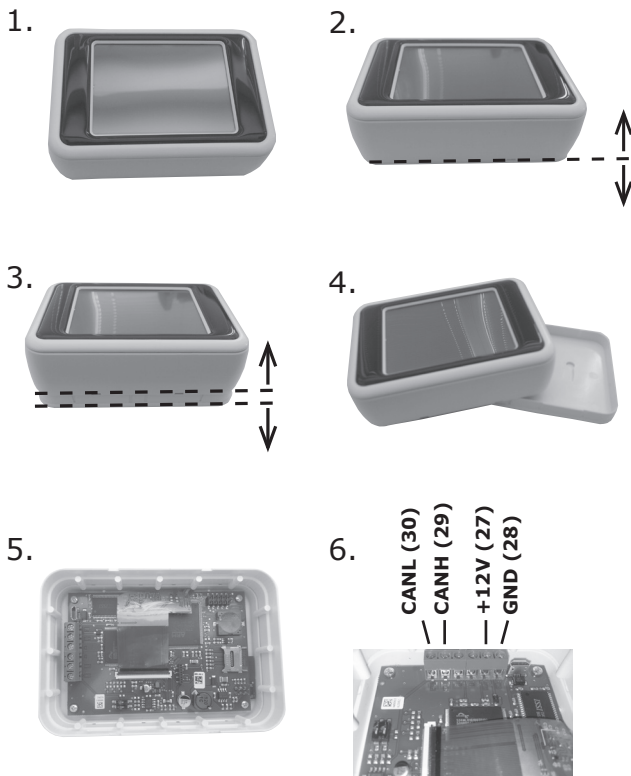

- Insert the other end of the cable to one of the connectors on the control computer board.

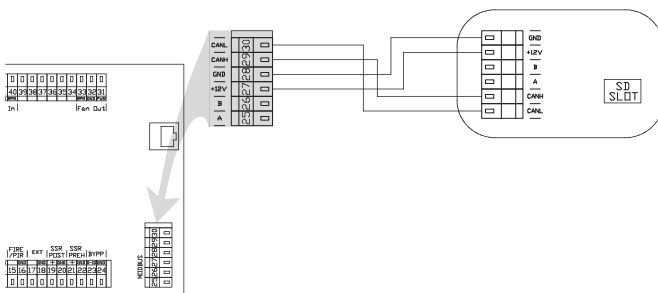

🔍 READ CAREFULLY!

- The supply and the control cable should be as far apart from each other as possible.
- Make sure that the cable has been properly connected at screw terminals.
- Be careful not to damage cable insulation when fixing the control panel to the wall or to other surface.
- If you do not connect cables directly during the unit's installation, protect them against mechanical damage or short circuit with insulating tape.
- Cable connectors must not come into contact with water or other liquid.

4.4.4 CONNECTING UNIT TO BMS CONTROL SYSTEM

The HRV unit's control includes the RS-485 interface. Connect the HRV computer control with a standard Cat6, RJ45 communication cable. Insert the cable BMS end into one of the connectors on the HRV unit's computer control board. Connect the other end to the main BMS end computer control.

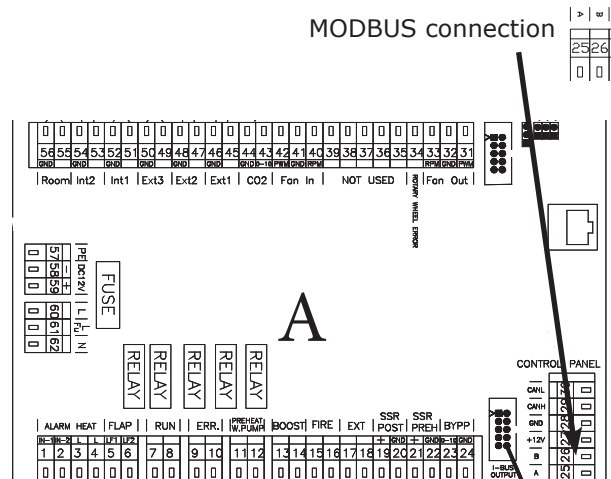

INSTALLATION

4. INSTALLATION

4.5 PROCEDURE FOR SBC100 WIRING

1. Ensure the ventilation unit is powered down.
2. Unbolt and open the service door and pull out the regulator tray.
3. Route the cat5e/6 cable (blue cable in images below) from the SBC100 (ETH1) through the building and into the ventilation unit via the grommet at the bottom (illustrated to the right).
4. Route the cat5e/6 cable along the service loop, through the wire ducts, and then terminate at the ethernet port on the Module A board on the regulator tray (illustrated below).
5. Push the tray back to its original position. Close and bolt the service door.
6. Power the unit back on.

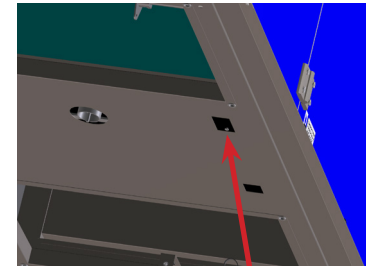
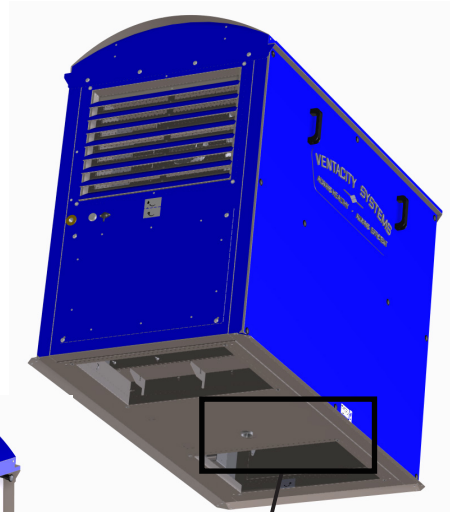

SCHEMATIC

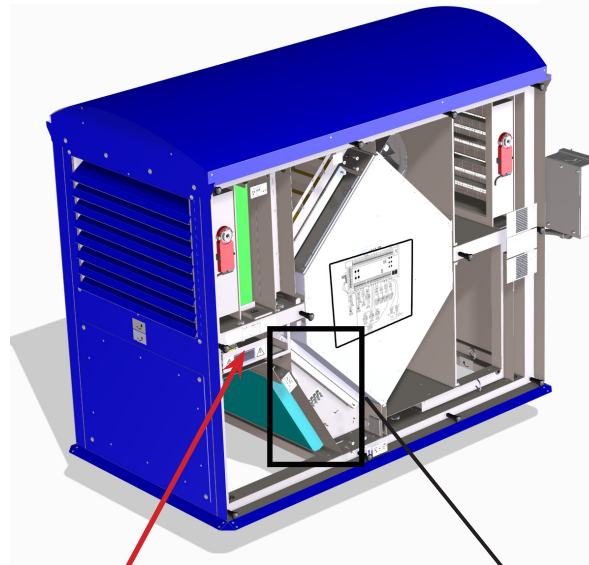
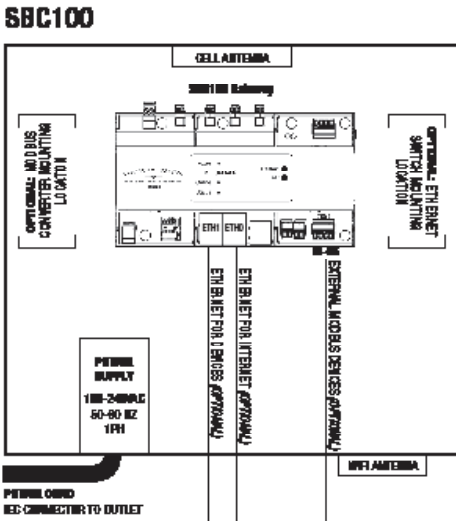

Regulator Tray

cat5e/6

Service Loop

Grommet for Wiring Egress

VENTILATOR

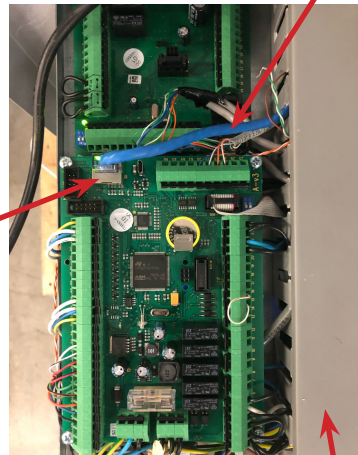
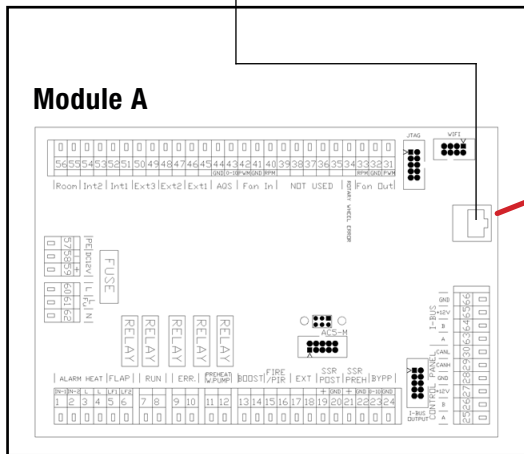

Wire Ducts



NOTE: blue cat5e/6 cable is not visible in this image as it is routed in the wire duct.

INSTALLATION

4. INSTALLATION

4.6 DEACTIVATE PREHEATER

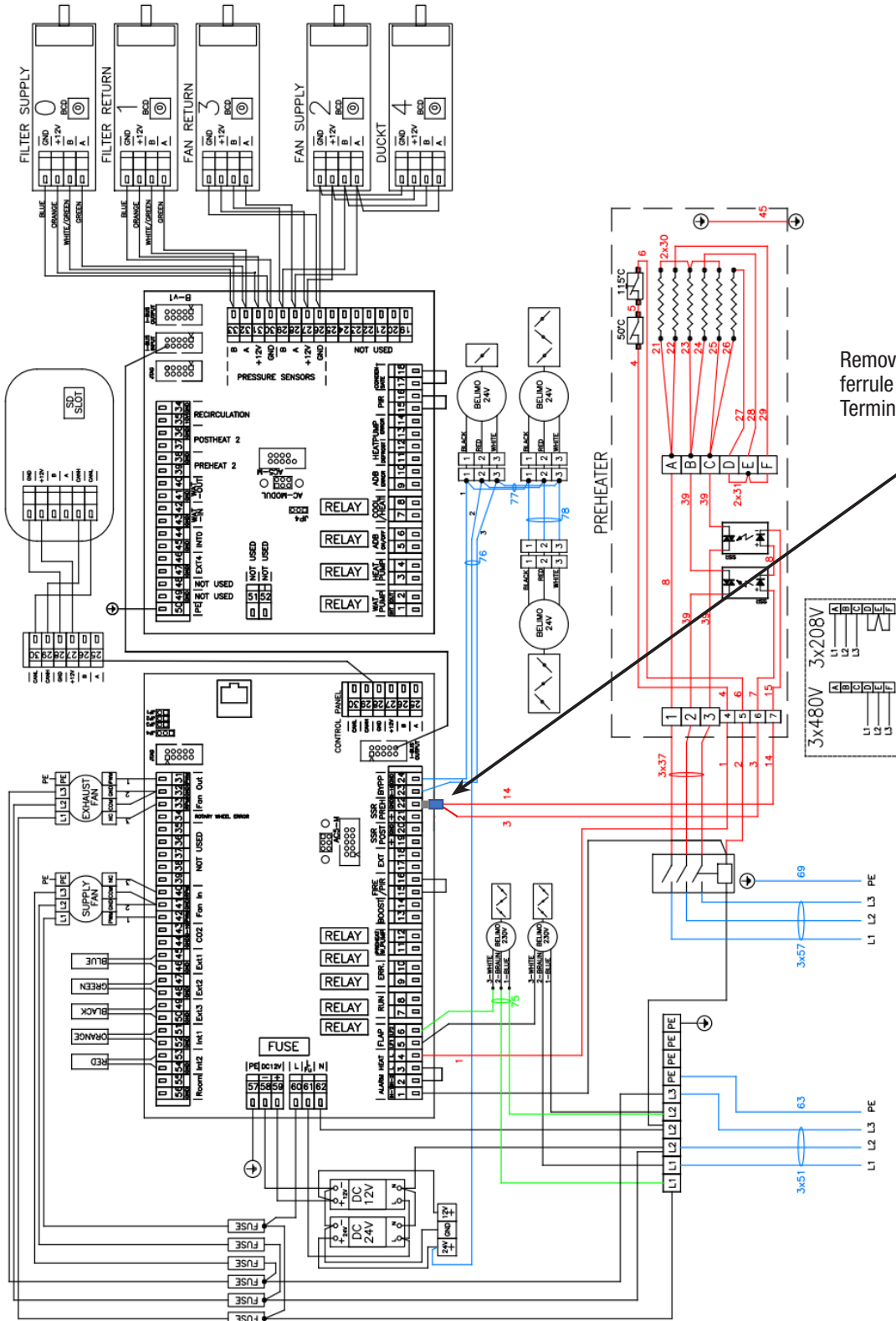

Remove wire from terminal 21 and ferrule with wire from terminal 22. Terminate ferrule at terminal 22.

5. COMMISSIONING

Programming The Controls

READ CAREFULLY

Verify the following points before putting the unit into operation:

- The HRV is securely attached to the supporting structure.
- The unit is closed correctly (rain louvers, ducts, etc.) and no rotating or heating component is exposed to human contact.
- The wiring is connected properly, including grounding and protection against external activation.
- All accessories are connected correctly.
- The condensation drain is properly connected to the discharge piping and the drain is filled with water.
- All connections comply with instructions in this manual.
- No tools or other objects have been left inside the unit as this could result in damage to the unit.

ATTENTION!

- *Any changes or modifications to unit wiring are prohibited and may void the warranty!*
- *We recommend using only accessories supplied by our company. If you have questions, please contact Ventacity Systems.*

READ CAREFULLY

- *Read the entire commissioning section before programming the HRV.*

5.1 ACTIVATION

Put the unit into operation (Stand-by) by turning the main switch to position 1 (ON). When the main switch is turned on, the control panel's display lights up and the service data loads. The unit is ready to start once the service data has loaded.

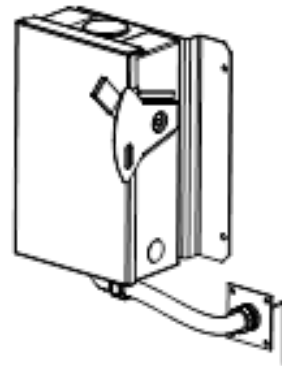

The control panel is provided with a touch sensitive display—the unit is controlled by touching symbols on the display.

Activate

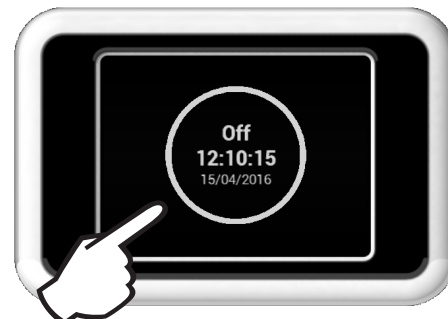

5. COMMISSIONING

5.2 MAIN DISPLAY - RUNNING

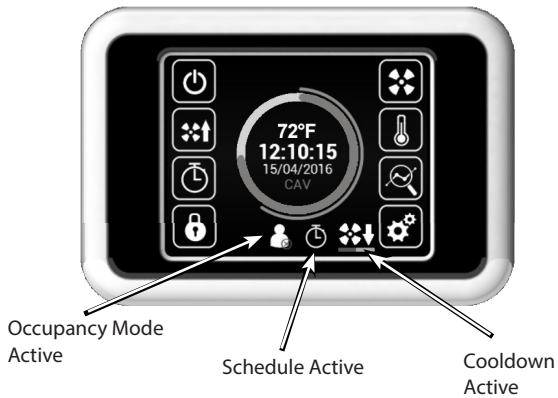
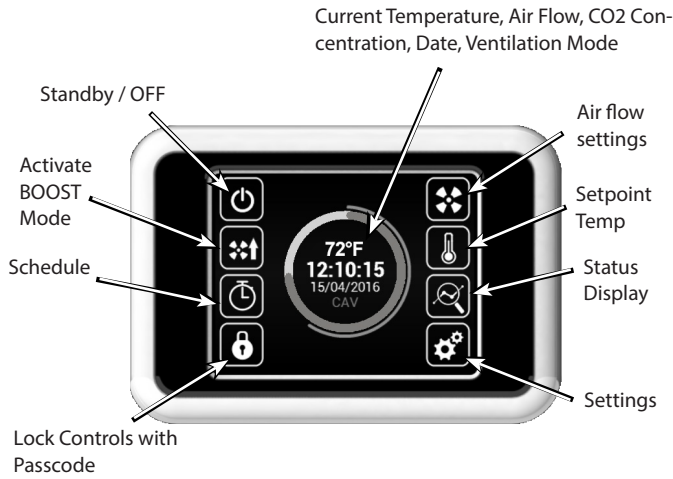

STATUS DISPLAY

This screen shows the status of the unit and present sensor values

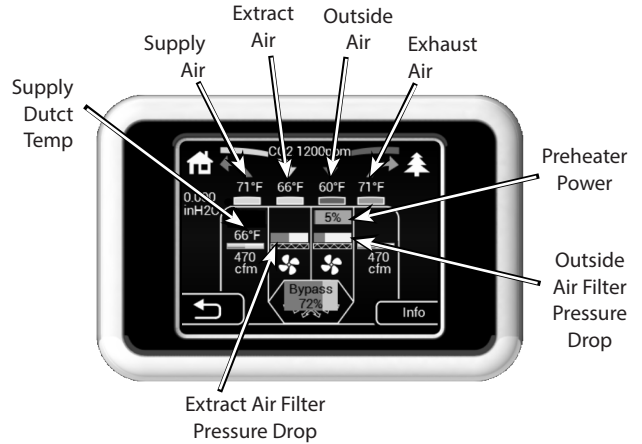
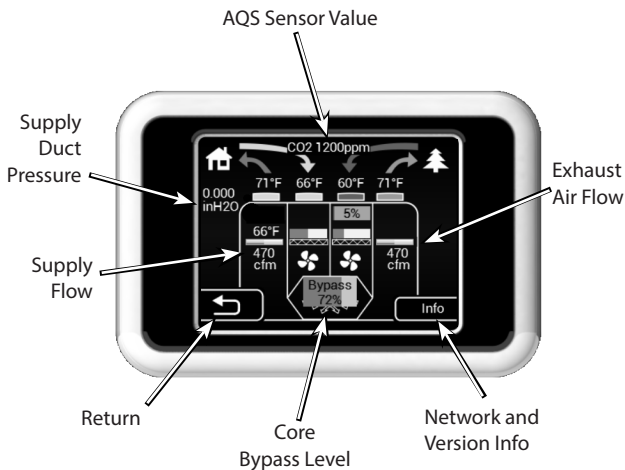

5.3 MAIN MENU

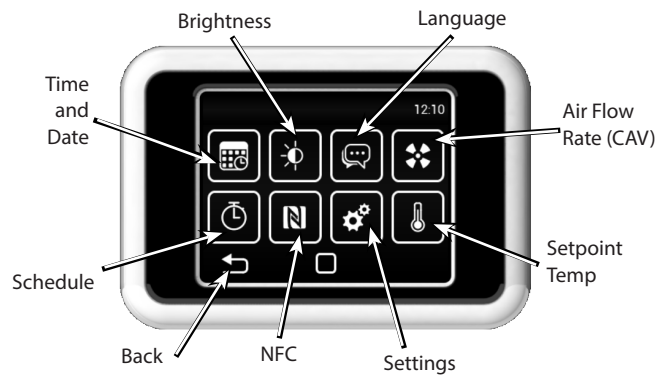

5.4 SERVICE MENU

Enter code 1616 to access the service menu.



5. COMMISSIONING



Navigate the menu by scrolling up and down on the touch screen.

MENU 01 - MODE

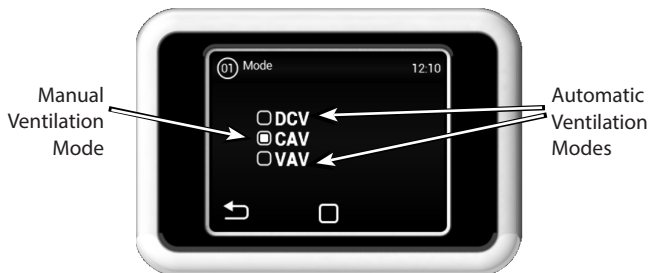

Manual CAV (*Constant Air Volume*) Temperature controlled fresh outside air is supplied to the building at a constant rate as set on the control panel.

Auto DCV (*Demand Controlled Ventilation*) Airflow into the building is modulated in response to readings from a variety of Indoor Air Quality (IAQ) sensors. When properly configured, this mode can provide significant energy savings by not over-ventilating while also ensuring no areas suffer from poor IAQ as a result of under-ventilation. Sensor types available from Ventacity Systems include CO₂, Relative Humidity (RH), and Volatile Organic Compounds (VOC). The VS3000 RT also features support for any other external 0-10V IAQ sensor.

Auto VAV (*Variable Air Volume*) Airflow is automatically controlled to maintain a constant pressure in the supply duct. As such, total flow will be reduced if the inlet to a ventilated room is closed off and increased if an inlet is opened. Through the use of flow control dampers, whether manually or electronically actuated, airflow can be precisely and efficiently tailored to the ventilation needs of multiple zones.

MENU 02 - HW SETTING

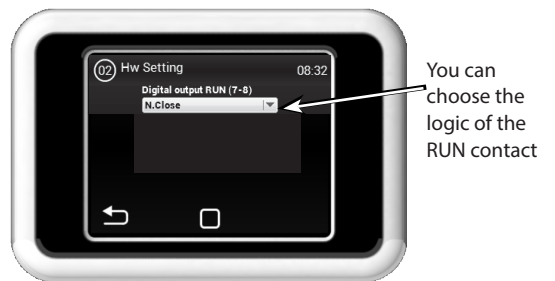

This menu lets you select the logic using with the digital input and the RUN output.
Input (7-8) - The logic of the connected RUN contact can be set as follows: as N. Close (normally closed) or N. Open (normally open)

MENU 04 - FAN CALIBRATION



5. COMMISSIONING

The calibration takes several minutes. Do not disconnect the unit, wait until it's completed. During the calibration the unit determines the maximum pressure loss, when the fan runs at full rate.

⚠ READ CAREFULLY! The unit will not work properly if, during calibration, the distribution network is not complete, the flaps or valves are not closed, etc.



MENU 05 - FILTER CALIBRATION

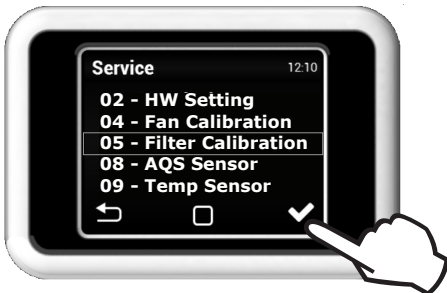

The calibration has to be carried out during the first commissioning and when switching to a new type of filter.

MENU 08 - AQS SENSOR

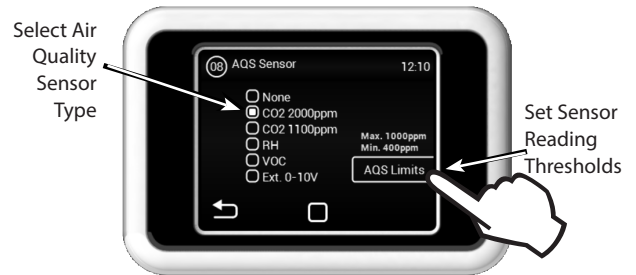

⚠ READ CAREFULLY!

Select the type of sensor connected to the unit. Select NO if no sensor is connected. If the correct parameters are not set, the unit may give an error message and not operate properly.



Select the minimum and maximum threshold values for Air Quality Sensor.

The HRV will run at the minimum flow rate when the sensor reading is at or below the minimum threshold. Airflow is increased in a linear fashion as the reading increases until maximum system flow rate is reached at the max threshold.

Breathing in DCV

When enabled, the flow rate is set to 0 CFM until the sensor reading is above the minimum threshold. To obtain an accurate reading of air quality, the unit will periodically run at an increased flow rate for a short period of time to circulate air through the system.

MENU 09 - TEMPERATURE PROBE



Choose the sensor to be used for maintaining the set point temperature

⚠ Note: Enabling room temperature requires an additional accessory sensor

5. COMMISSIONING

MENU 10 - SUPPLY DUCT LIMITS

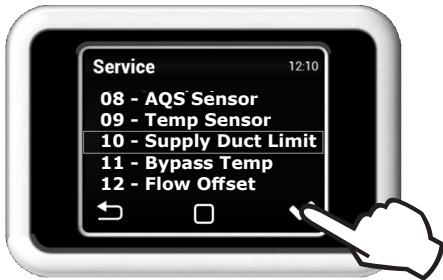

Enable or disable reduction of air flow if the minimum duct temperature cannot be achieved (enabled by default)

Set maximum supply air temperature

Set minimum supply air temperature

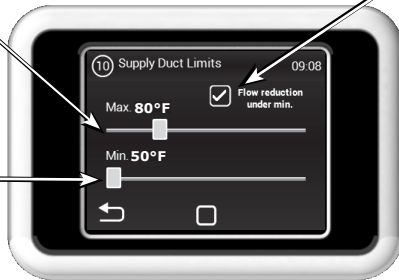

It is recommend to leave flow reduction enabled.

! If the sensor in the supply ventilation shaft is set, the maximum temperature in the duct can not be configured

MENU 11 BYPASS TEMPERATURE

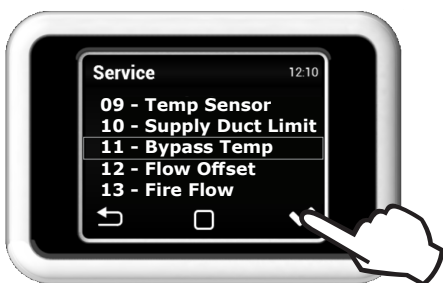

Minimum external air temperature at which the BY-PASS opening is authorised.
Range 32-68°F.

MENU 12 - FLOW OFFSET

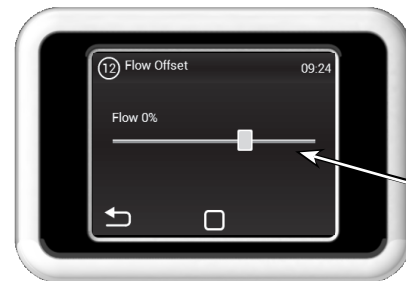

Set the fans offset (overpressure, underpressure)

If you need over- or under-pressure ventilation, you can set a constant difference of speeds between the supply and the exhaust fan. These settings and schemes relate to the air flow at high fan speeds.

MENU 13 - FIRE FLOW



5. COMMISSIONING



Setting the unit's rate when the FIRE contact opens (input terminals 15-16)

Fire flow modes:

- Flow off
- Flow supply + exhaust
- Flow only supply
- Flow only exhaust

! The FIRE input has the highest priority (it disables all the other modes, including anti-freeze protection)

MENU 13 - OCCUPANCY

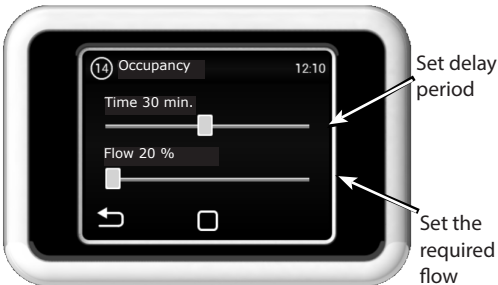

While presence is detected, the scheduled settings will run as normal. After no presence has been detected for the specified amount of time, the system will run at the flow rate set here until presence is detected again.

In the occupancy sensor mode the temperature cannot be regulated.

Note: The occupancy sensor available as an accessory from Ventacity Systems is preset. Therefore, it is not necessary to set the delay.

MENU 15 - BOOST



Time interval for which the mode is activated after the BOOST contact is activated

Allow to activation of BOOST mode with the unit in stand-by mode

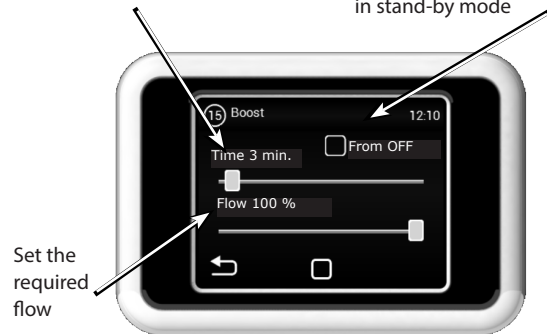

! Boost can be activated with the button connected to the input 13/14, or with the Boost button on the main screen

Note: BOOST mode is not compatible with the Multizone mode.

After activation of the Boost mode (the mode can be activated on main display or optional external trigger), the unit operates in pre-set speed for pre-set time period. (Maximum duration is 60 min.)

5. COMMISSIONING

MENU 16 - FREECOOLING

The Freecooling function is designed to utilize cool night air during warmer months to "pre-cool" the building prior to occupancy. In this mode, the heat exchanger core is bypassed fully (recuperation is undesirable at this time) and the HRV runs at the predetermined flow rate.

For the HRV to enter Freecooling mode, all of the following conditions must be met:

- Freecooling enabled
- Time and date within permitted range
- $T-EXT1 \leq T-INT1 - 37.4^{\circ}F$
- $T-INT1 > \text{Freecooling setpoint}$

In order to accurately assess these conditions, a Pre-Freecooling mode will activate:

- If within the permitted Freecool time frame
- If there is no airflow through the unit
- In this mode, fan speed is increased for ten (10) minutes each hour to circulate air through the ducts and obtain an accurate measurement of environmental conditions.

While functioning in Freecooling Mode, the HRV:

- Runs fans at rate specified in settings menu
- Varies bypass damper as necessary to maintain minimum duct temperature

If during Freecooling functionality, any of the following conditions are met, the mode will terminate.

- Current time no longer within permitted window
- $T-INT1 \leq T-EXT1$
(Building is same temp as ambient)
- $T-INT1 \leq \text{Temp in Freecooling settings}$
- User Intervention

Once terminated, Freecooling will not restart until the next time and date window, if still enabled.

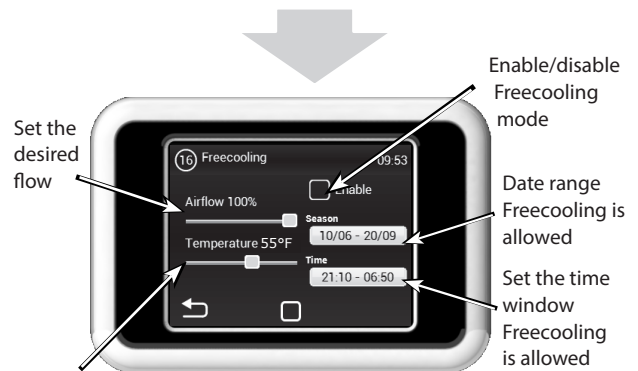
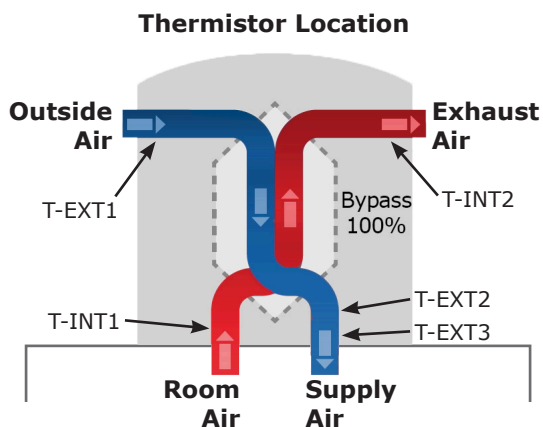

Set the target temperature (measured at the Extract duct sensor).

! Freecooling is assessed also if the unit is in stand-by (at a selected time and date the unit starts-up and assesses if the freecooling may be activated - see Pre-freecooling above)

MENU 17 - PID PARAMETERS

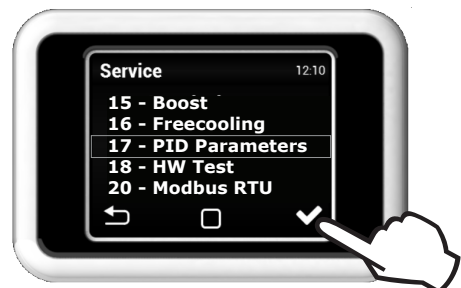

Setting control features. If the control is unsteady or variable, this configuration can be done only after consulting the manufacturer.

5. COMMISSIONING

MENU 18 - HW TEST

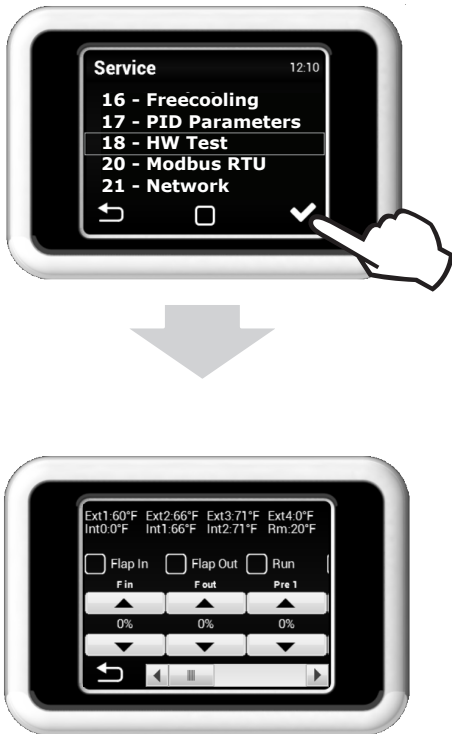

The HW TEST menu is used to test all the connected components and accessories. These parameters are not stored and the HRV will return to normal operation upon exiting this screen

Warning: This mode allows explicit control of the components in the HRV. There are no protections in place to stop a user from operating the unit in a potentially hazardous manner.

The heater(s) should not be manually operated with the dampers closed nor without adequate airflow through the HRV.

F in	Supply Fan
F out	Exhaust Fan
Pre 1	Preheater 1 Power
By/Ro	Core Bypass
Ext 1	Outside Air
Ext 2	Supply Air (Post Heat Exchanger)
Ext 3	SA (In-Duct)
Int 1	Extract Air
Int 2	Exhaust Air

MENU 20 - MODBUS RTU

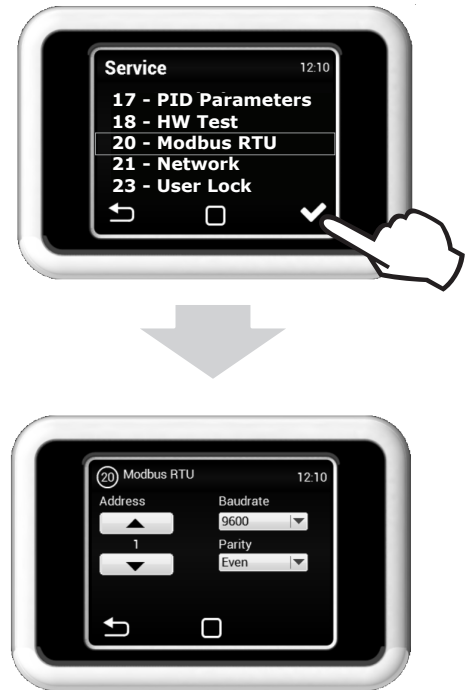

The MODBUS menu is used to set the Modbus communication.

MENU 21 - NETWORK PARAMETERS

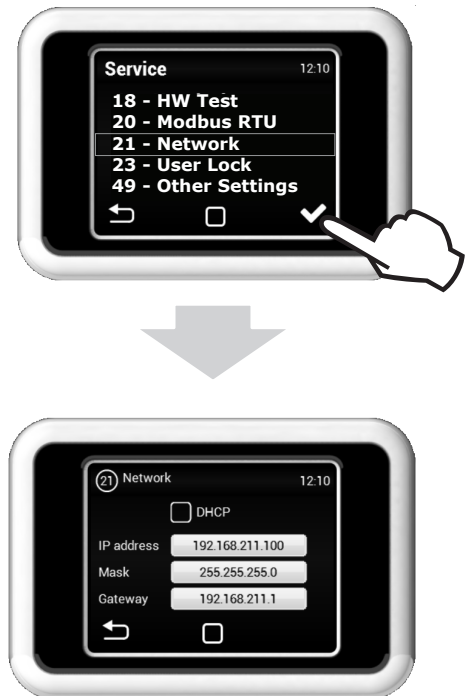

The NETWORK is used to set the unit's IPv4 configuration for ModBus TCP.

5. COMMISSIONING

MENU 23 - USER LOCK

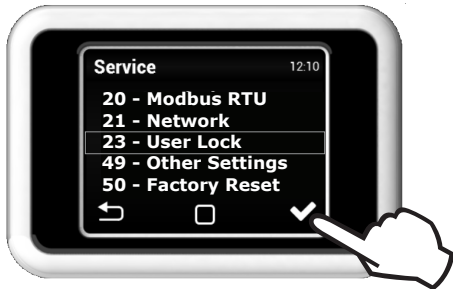

Several security levels can be chosen:

ON/OFF

The unit can be turned on or off without password.

ON/OFF, Temp, Flow

Allows unit to be turned on or off, set the required temperature and air flow without password.

Temp, Flow

Allows to set the required temperature and air flow without password.

Full

Does not allow any settings without password.

User Mode

The unit can be turned on or off and the required temperature and air flow can be set without password.



⚠ After entering the password, the unit can be fully controlled and set.

MENU 49 - OTHER SETTINGS

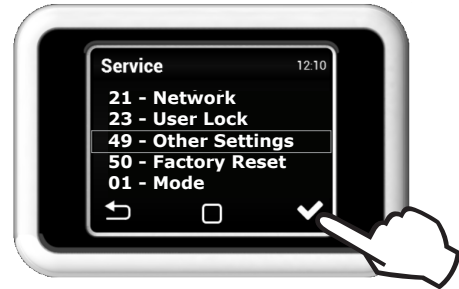

Activation unit of the second control panel

MENU 50 - FACTORY RESET

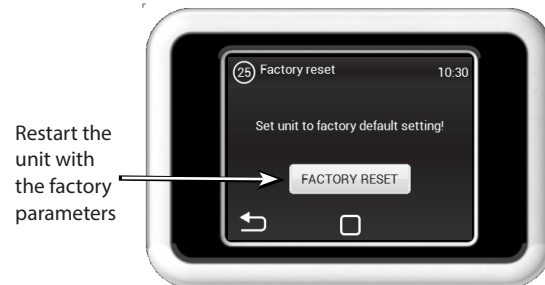

Restart the unit with the factory parameters



It does not change
 - Settings like AQS
 - Ventilation mode
 - HW settings
 - Temperature sensor
 - ModBus settings

6. REFERENCE

6.1 MAINTENANCE

6.1.1 Replacing A Filter

It is recommended to perform a visual inspection of the filter at least once every 3 months. If the user interface panel flags an alarm that a filter is restricted, replace all filters immediately.

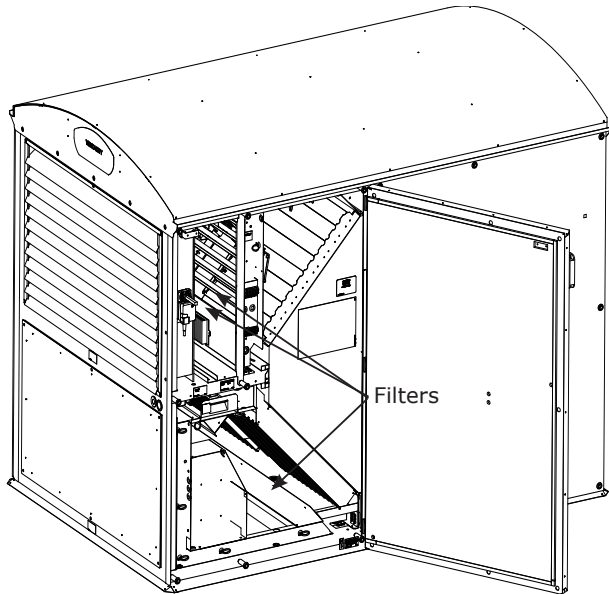

1. Open the side panel.
2. Pull out the filters.
3. Insert new filters and replace the side panel.

FILTER SPECIFICATIONS

Filter Type	Ventacity Part Number	Actual Dimensions
Outside Air	1009131	23.375" x 23.375" x 3.75"
Outside Air Pre	1009124	26.375" x 25.625" x 1.75"
Return Air	1009125	25" x 25.625" x 3.75"

READ CAREFULLY!

Warning icon will automatically disappear.

ATTENTION!

Unit's performance may be reduced and the fan can be damaged if the filter is not properly cleaned or replaced.

6.1.2 Cleaning Intervals

YOU WILL NEED

- Vacuum cleaner
- Brush
- Cloth
- Neutral cleaning agent (soapy water)

It is recommended to check and clean the unit every six months; however, the intervals must be adapted to specific operating conditions. It is recommended to thoroughly clean the unit once a year.

If the unit is not in use for a long time, it is recommended to turn it on for about an hour every six months.

Follow the same procedure as when replacing the filter (see Section 6.1.1).

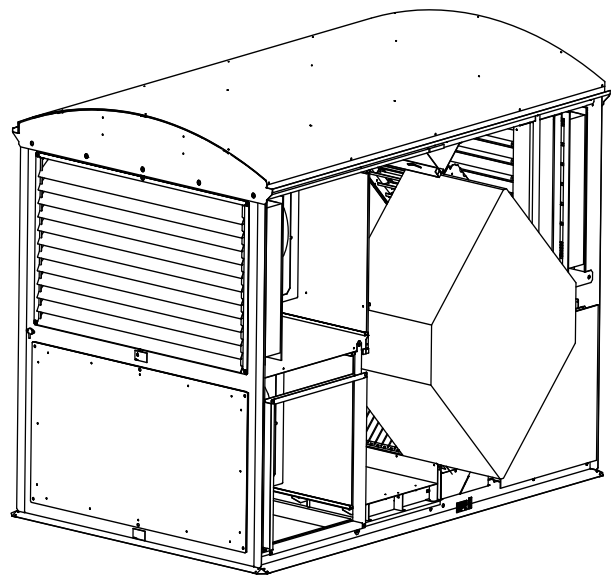

Clean the HRV unit with a vacuum cleaner, brush, cloth, and soapy water.

To clean the heat exchanger, pull out, half way, to the rear with the nylon pull strap. Vacuum and wash the rear portion. Then, pull the heat exchanger half way out in the front direction, and vacuum and wash.

Do not use sharp objects, harsh chemicals, solvents, abrasive cleaners, high-pressure washers, compressed air, or steam.

6. REFERENCE

6.2 TROUBLESHOOTING

⚠ ATTENTION!

- Before starting the maintenance and repair works, the unit must be disconnected from the power sources, the supply voltage must be locked, and the service switches must be in position 0 (off).
- Do not attempt repairs if you are not familiar with the exact procedure. Contact a qualified service provider.

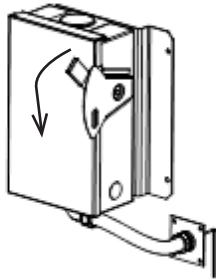

⚙ TECHNICAL DATA

An error is usually indicated by a message on the display. See the table below.

Description	Behavior	Likely problem	Solution
4 – Supply fan error	Unit is not working	Overheated fan or defect on thermal contact of inlet fan	Determine the cause of the overheating (defective bearing, short-circuit...) or replace the engine.
5 – Exhaust fan error	Unit is not working	Overheated fan or defect on thermal contact of inlet fan	Determine the cause of the overheating (defective bearing, short-circuit...) or replace the engine.
6 – Inlet filter clogged	Unit is ventilating	Clogged filter	Check the condition of the filter, or replace it. If the unit does not have a pressure sensor for the filter, RESET the clogged filter according to the manual.
7 – Exhaust filter clogged	Unit is ventilating	Clogged filter	Check the condition of the filter, or replace it. If the unit does not have a pressure sensor for the filter, RESET the clogged filter according to the manual.
8 - Failure in preheating 1	Unit is ventilating	Overheated electric exchanger or damaged sensor Open the exchanger thermostat.	Check that air can flow freely through the unit, electric heat exchanger is not cooling sufficiently. Check the safety thermostat on the electric preheating for damages.
9 - Failure in exchanger 1	Unit is ventilating	Overheated electric exchanger or damaged sensor Open the exchanger thermostat.	Check that air can flow freely through the unit, electric heat exchanger is not cooling sufficiently. Check the safety thermostat on the electric reheating for damages.
10 - Failure in exchanger 2	Unit is ventilating	Overheated electric exchanger or damaged sensor Open the exchanger thermostat.	Check that air can flow freely through the unit, electric heat exchanger is not cooling sufficiently. Check the safety thermostat on the electric reheating for damages.
11 - Failure in preheating 2	Unit is ventilating	Overheated electric exchanger or damaged sensor Open the exchanger thermostat.	Check that air can flow freely through the unit, electric heat exchanger is not cooling sufficiently. Check the safety thermostat on the electric preheating for damages.

6. REFERENCE

Description	Behavior	Likely problem	Solution
12 – CO2 sensor failure	Unit is ventilating	Defective air quality sensor	Check that the CO2 sensor is connected correctly or check that it is operating correctly (output signal value)
13 - Failure of rotary heat exchanger	Unit is not working	Failure of rotary heat exchanger	Check that the input error is correctly connected to the electronics or check what type of error the heat exchanger is indicating.
14 - ADB module error	Unit is ventilating	Failure of adiabatic module	Check that the input error is correctly connected to the electronics or, if necessary, that the adiabatic module is operating correctly
15 - Heat pump error	Unit is ventilating	Heat pump failure	Check that the input error is correctly connected to the electronics or, if necessary, that the heat pump is operating correctly (according to the instructions of its manufacturer)
16 – Inlet – External temperature sensor failure (T-EXT1)	Unit is not working	Room temperature sensor failure	Check that the sensor is correctly connected to the electronics or test it measuring its resistance (the resistance value at +68°F is around 10kΩ)
17 – Inlet – Failure of the temperature sensor behind the exchanger (T-EXT2)	Unit is not working	Room temperature sensor failure	Check that the sensor is correctly connected to the electronics or test it measuring its resistance (the resistance value at +68°F is around 10kΩ)
18 – Inlet – Temperature sensor failure in the supply canal (T-EXT3)	Unit is not working	Room temperature sensor failure	Check that the sensor is correctly connected to the electronics or test it measuring its resistance (the resistance value at +68°F is around 10kΩ)
19 - Inlet - Temperature sensor failure after the second exchanger (T-EXT4)	Unit is not working	Room temperature sensor failure	Check that the sensor is correctly connected to the electronics or test it measuring its resistance (the resistance value at +68°F is around 10kΩ)
20 - Exhaust – Temperature sensor failure in the exhaust canal (T-INT0)	Unit is not working	Room temperature sensor failure	Check that the sensor is correctly connected to the electronics or test it measuring its resistance (the resistance value at +68°F is around 10kΩ)
21 – Exhaust – Temperature sensor failure in the exhaust canal (T-INT1)	Unit is not working	Room temperature sensor failure	Check that the sensor is correctly connected to the electronics or test it measuring its resistance (the resistance value at +68°F is around 10kΩ)
22 – Exhaust – Failure of the temperature sensor of the exchanger's anti-freeze protection (T-INT2)	Unit is not working	Room temperature sensor failure	Check that the sensor is correctly connected to the electronics or test it measuring its resistance (the resistance value at +68°F is around 10kΩ)
23 - Temperature sensor failure of the exchanger's water supply (T_WATER_IN)	Unit is not working	Room temperature sensor failure	Check that the sensor is correctly connected to the electronics or test it measuring its resistance (the resistance value at +68°F is around 10kΩ)
24 - Failure in the return water sensor of exchanger (T_WATER_OUT)	Unit is not working	Room temperature sensor failure	Check that the sensor is correctly connected to the electronics or test it measuring its resistance (the resistance value at +68°F is around 10kΩ)
25 - Room temperature sensor failure (T_ROOM)	Unit is ventilating	Room temperature sensor failure	Check that the sensor is correctly connected to the electronics or test it measuring its resistance (the resistance value at +68°F is around 10kΩ)

6. REFERENCE

Description	Behavior	Likely problem	Solution
26 - Failure in the pressure sensor of the exhaust filter.	Unit is ventilating	Pressure sensor failure	Check the supply point for mechanical damage or whether it is clogged by dirt, or whether the supply hoses are free. The pressure sensor will likely need to be replaced
27 - Failure in the pressure sensor of the inlet filter	Unit is ventilating	Pressure sensor failure	Check the supply point for mechanical damage or whether it is clogged by dirt, or whether the supply hoses are free. The pressure sensor will likely need to be replaced
28 - Failure in the pressure sensor of the inlet fan	Unit is not working correctly	Pressure sensor failure	Check the supply point for mechanical damage or whether it is clogged by dirt, or whether the supply hoses are free. The pressure sensor will likely need to be replaced
29 - Failure in the pressure sensor of the exhaust fan	Unit is not working correctly	Pressure sensor failure	Check the supply point for mechanical damage or whether it is clogged by dirt, or whether the supply hoses are free. The pressure sensor will likely need to be replaced
30 - Failure in the pressure sensor of the VAV supply channel	Unit is not working correctly	Pressure sensor failure	Check the supply point for mechanical damage or whether it is clogged by dirt, or whether the supply hoses are free. The pressure sensor will likely need to be replaced
31 - Failure in the pressure sensor of the VAV C4 exhaust channel	Unit is not working correctly	Pressure sensor failure	Check the supply point for mechanical damage or whether it is clogged by dirt, or whether the supply hoses are free. The pressure sensor will likely need to be replaced
32 - Air quality sensor failure	Unit is ventilating	Defective air quality sensor	Check that the quality sensor is connected correctly or check that it is operating correctly (output signal value)
33 - Failure in the recirculation relative humidity sensor	Unit is ventilating	Defective relative humidity sensor	Check that the humidity sensor is connected correctly or check that it is operating correctly (output signal value)
34 - Failure in the sensor of external temperature from BMS	Unit is ventilating	Defective sensor in BMS or incorrectly received data	Check that the address and values of the sensor in the BMS system are correct. Check that the sensor in the BMS system is working.
35 - Failure in the REK antifreeze protection relative humidity sensor	The unit is ventilating th	Defective relative humidity sensor	The communication cable to the relative humidity sensor is damaged or disconnected. The humidity has exceeded the permitted limit and the sensor may temporarily read incorrect values. Check the connection of the sensor. Set its address and check that it is not flooded. Replace if necessary.
36 - Module B error	Unit is not working	The unit cannot control the peripherals connected to Module B	Unable to communicate with module B. Check whether the communication cable between control boards A and B is damaged. If necessary, replace module B.
37 - Condensate pan overflow	Unit is not working	The level sensor has detected an extremely high level of water in the condensate pan	Check that the level sensor is connected correctly or check that it is operating correctly, or whether the condensate drain is clogged, preventing the condensate from draining properly.
50 - Inlet filter clogged > 80%	Unit is ventilating	Clogged filter	Filter change recommended
51 - Exhaust filter clogged > 80%	Unit is ventilating	Clogged filter	Filter change recommended
70 - Anti-freeze protection of the water heat exchanger	Unit is ventilating	The anti-freeze protection of the water heat exchanger is active	The automatic protection of the water exchanger has been activated in order to prevent damages due to low temperature. This is an autonomous function and will be terminated once the risk of frost disappears.

6. REFERENCE

Description	Behavior	Likely problem	Solution
71 - Water heater - waiting for water temperature	Unit is ventilating	The unit controls the temperature of the liquid in the exchanger	The automatic process that assesses the water temperature in the exchanger to activate the next steps is in progress
72 - Water heater - waiting for supply air temperature	Unit is ventilating	The unit controls the temperature of the air flowing through the exchanger	The automatic process that assesses the temperature of the air flowing through the exchanger to activate the next steps is in progress
73 - WCO detects temperature of the water supply (cold/hot)	Unit is ventilating	The unit controls the temperature of the liquid in the exchanger	The automatic process that assesses the water temperature in the exchanger to activate the next steps is in progress
73 - Pre-Freecooling active	Unit is ventilating	Temperature evaluation for freecooling mode is in progress	Preparation for freecooling mode is in progress. it evaluates the temperature and the conditions necessary to activate this mode.
74 - Flow reduction, minimum temperature in the duct not reached	Unit operates in a restricted mode	The unit is trying to reach the set values of the duct min temp	The temperature of the air flowing into the inlet branch of the building has not been reached. The performance of the unit is being automatically corrected to reach this minimum level. Automatic process.
75 - Passive house protection	Unit is not working	The unit is operating in order to meet the Passive House specifications	The temperature of the air flowing into the inlet branch of the building is not within the Passive House specifications. The performance of the unit is being automatically corrected to reach this minimum level. Automatic process.
76 - Heat pump defrost	Unit operates in a restricted mode	The unit is waiting until the heat pump defrosts	The heat pump is reporting that it is defrosting. The unit is operating in defrost-waiting mode. Automatic process.

Location of fuses on the "A" control board

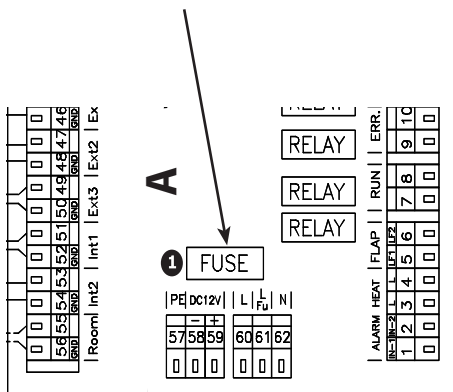

Fuses on the cont board:

T2A 5x20mm 250V

Fuses engine:

information is placed on the label next to the fuse box, or directly on the fuse

READ CAREFULLY!

In case of power failure and subsequent recovery of the power supply, the unit returns to its state before the failure. The unit always remembers its operating status and configuration.

If you fail to find or remove the cause of the error, or if the repair requires intervention in the unit, contact an authorized service provider.

6. REFERENCE

6.3 SERVICE

6.3.1 If The Error Persists

If you cannot resolve the error, please contact the supplier.

READ CAREFULLY!

Provide the following information to facilitate correcting the error:

- Product type
- Serial number
- Operating time
- Used accessories
- Unit location
- Connection conditions (including electrical conditions)
- Detailed description of the error and steps taken to remove it.

6.3.2 Decommissioning and Product Disposal

Please make sure the unit is inoperative before disposal. Older units also include reusable materials. Take them to a waste separation site.

The product should be dismantled in a specialized center so that the recyclable materials can be reused. Parts that cannot be recycled should be taken to a legal waste disposal site.

Materials must be disposed of in accordance with applicable national regulations and directives.

This product must be disposed of in accordance with local laws and regulations.

The product contains batteries and therefore it must be recycled or disposed of separately from household waste. When the battery or the product reaches the end of its service life, contact your dealer or local authorities and ask about recycling options. The separate collection and recycling of your product and its battery will help to preserve natural resources and ensure that the product will be recycled in a manner that protects human health and the environment.



6.3.3 How to Find Firmware Version & Serial Number

On the Control Panel, navigate to the Status Display (as illustrated below). Press the "Info" tab on the bottom right corner of the status display screen. This will bring up the information screen.

STATUS DISPLAY

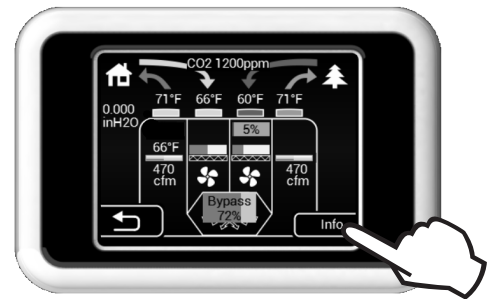

SERIAL NUMBER: On the information screen, locate the line with "SN: [nnnnnnnnnn]" where [nnnnnnnnnn] is the unit's serial number.

MODULE-A FW VERSION: On the information screen, locate the line with "BL: [aaa] Firmware Module-A: [bbb]" where [aaa] is the boot-loader version and [bbb] is the Module-A firmware version.

CONTROL PANEL FW VERSION: On the information screen, locate the line with "BL: [ccc] Firmware CP: [ddd]" where [ccc] is the boot-loader version and [ddd] is the control panel firmware version.

6.4 ACCESSORIES

VS1000RT ACCESSORY LIST		
Ventacity Part Number	Ventacity Model Number	Description
1083011	VS-CO2-INT	Room CO2 Sensor
1010002	VS-CO2-DUCT	Duct CO2 Sensor
1068000	SBC100	Smarter Building Controller

6. REFERENCE

6.5 CONCLUSION



Please read this manual carefully and follow its instructions to ensure correct and safe operation of the Heat Recovery Ventilator unit.

Should you have any questions or require some additional explanation, please do not hesitate to contact our sales department or technical support.

Contact information:

Ventacity Systems, Inc.
2121 NE Jack London Street
Suite 120
Corvallis, Oregon 97330 USA

Phone: 1-503-208-7331
Website: www.ventacity.com
support@ventacity.com
1-833-HELP-VENT
1-833-435-7836

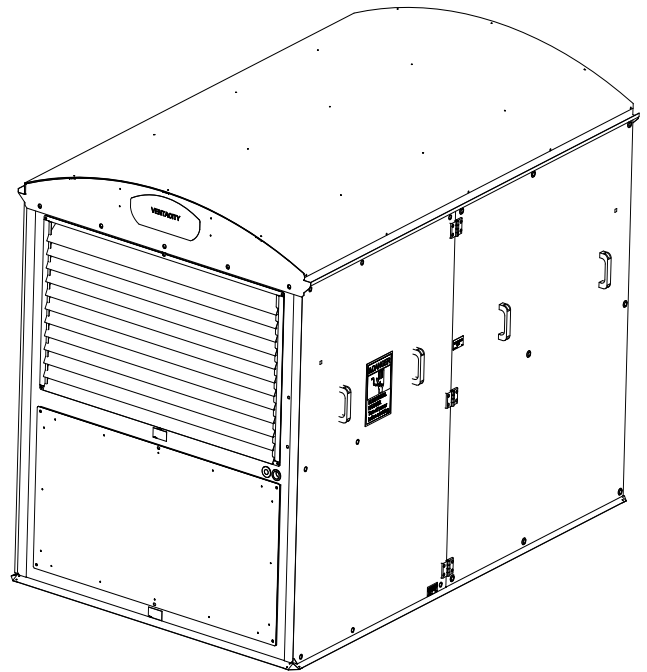

Copyright © 2026 Ventacity Systems, Inc.
All rights reserved.

The manufacturer is not liable for any damage to the product arising from unauthorized installation and operation inconsistent with regular conventions for installation and operation of air-conditioning units and regulation systems.